

Price

Fifty

Cents.

THE NEW YORK
PUBLIC LIBRARY

PATTEN'S

CAVALRY DRILL

AND

SABRE EXERCISE,

COMPILED

Agreeably to the Latest Regulations of the War Department

FROM

STANDARD MILITARY AUTHORITY.

BY GEORGE PATTEN,

LATE OF THE UNITED STATES ARMY.



NEW YORK:

PUBLISHED BY J. W. FORTUNE,

No. 102 CENTRE STREET.

1864.

Entered according to Act of Congress
in the office of the District Court of
the Southern District of New York.

Copyright
year 1861, by JAMES WALDEN FORTUNE, in the
office of the Southern District of New York.

CAVALRY DRILL

AND

SABRE EXERCISE:

COMPILED

AGREEABLY TO THE LATEST REGULATIONS OF
THE WAR DEPARTMENT,

FROM

Standard Military Authority.

BY GEORGE PATTEN,

LATE OF THE U. S. ARMY.

NEW YORK:
PUBLISHED BY J. W. FORTUNE,
No. 102 CENTRE STREET.

1864.
A. C. H.

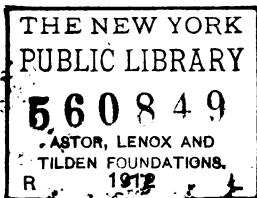

Entered according to Act of Congress, in the year 1961,

BY J. W. FORTUNE,

In the Clerk's Office of the District Court of the United States for the Southern
District of New York.

P R E F A C E.

THE following work is presented with the hope of meeting a want, now felt by the mounted troops called into service from civil pursuits. The knowledge of tactics acquired by militia seldom extends beyond the requirement of infantry movements, so that the number possessing an acquaintance with the drill and evolutions of mounted troops is comparatively small. It is therefore essential that the general principles of Cavalry Instruction, and the main details of the Cavalry Drill, should be speedily acquired by all entering this branch of service.

This book is designed to impart such instruction in a manner easily to be understood by the tyro in military knowledge; enabling the intelligent private to fully understand the various movements in which he takes a part, and affording the necessary instruction to officers to render them proficient in the various details of the schools of the Trooper, Platoon, and Squadron.

Besides which, the sabre exercise is given, with numerous illustrations of the several positions of attack

and defence. These, and the diagrams of the cavalry movements, are inserted with the text to which they belong; thus greatly facilitating reference to them.

By excluding from this work all instruction to mounted troops not embraced in the Army of the United States, the compiler has been enabled to present the authorized *cavalry drill* in such a form as to render this volume a suitable pocket companion for the cavalry soldier.

NEW YORK, October, 1861.

CONTENTS.

	PAGE
CAVALRY DRILL.....	5
PART FIRST—INSTRUCTION ON FOOT.....	5
Art. 1.—Definitions and General Principles.....	5
Art. 2.—School of the Trooper Dismounted.....	13
Art. 5.—The Sabre Exercise, Draw Sabre.....	13
Present—Sabre, Carry—Sabre, Return—Sabre.....	14
Inspection—(of) Sabre, Inspection—(of) Arms.....	15
Guard, Left—Moulinet.....	16
Right—Moulinet, Left and Right—Moulinet.....	17
Right and left—Moulinet.....	17
Bear—Moulinet, In Tierce—Point.....	18
In Quarte—Point, Left—Point.....	19
Right—Point, Rear—Point.....	20
Against infantry left—Point.....	21
Against infantry right—Point, Front—Cut.....	21
Left—Cut, Right—Cut.....	22
Rear—Cut, Right, in tierce and quarte—Cut.....	23
Left, in quarte and tierce—Cut.....	23
Rear, in tierce and quarte—Cut, In tierce—Parry.....	24
In quarte—Parry.....	24
For the head—Parry, Against infantry right—Parry.....	25
Against infantry left—Parry.....	26
PART SECOND—INSTRUCTION ON HORSEBACK.....	23
Art. 1.—To Conduct his Horse to the Ground.....	28
Position of the Trooper before Mounting.....	28
To Mount.....	29
To Lengthen the Reins of the Snaffle.....	32
To Shorten the Reins of the Snaffle.....	32
To Cross the Reins in the Left Hand.....	32
To Take the Reins in Both Hands.....	33
To Cross the Reins in the Right Hand.....	33
The Use of the Reins, The Use of the Legs.....	33
The Effect of the Reins and Legs Combined, To March.....	34
To Halt, To Turn to the Right, and to the Left.....	35
To Turn-about to the Right and to the Left.....	35
To Make a Quarter-turn to the Right and to the Left.....	36
To Rein-back, and to Cease Reining-back.....	36
To Mount.....	37
Length of the Stirrups, Position of the Foot in the Stirrup.....	38

	PAGE
Position of the Bridle-Hand with Curb.....	39
The Principal Movements of the Bridle-Hand.....	39
Art. 2—Manual of Colt's Revolver.....	40
PART THIRD—BASIS OF INSTRUCTION.....	44
Explanation of Signs.....	44
Post of the Officers and Non-Commissioned Officers of a Squadron in line.....	45
Posts of Officers of a Squadron in order of column of fours and twos.....	46
In column of Platoons.....	47
In column of Sections, In column of Divisions.....	48
Posts of Officers and Non-Commissioned Officers of a Company acting singly.....	49
Successive Alignment of Files in the Platoon.....	52
Alignment of the Platoon, To Open and Close the Ranks.....	54
To Rein Back the Platoon, To Break the Platoon by File.....	55
Direct March in Column by File.....	56
To Halt, and to commence the March in Column.....	56
Individual Oblique March.....	57
The Platoon Marching in Column by File.....	57
To Form Front in Line.....	57
To Form to the Left into Line.....	58
To Form on Right into Line.....	59
To Break the Platoon by Twos or by Fours.....	59
Direct March in Column by Twos or by Fours.....	60
Change of Direction.....	61
Individual Oblique March.....	62
The Platoon Marching in Column by Twos.....	63
To Form to the Front into Line.....	63
To Form to the Left into Line.....	64
To Form on the Right into Line.....	65
To Form the Platoon to the Left in One Rank.....	66
To Form the Platoon to the Left in Two Ranks.....	67
To Form Twos and Fours at the same Gait.....	68
To Break by Twos and by File at the same Gait.....	69
To Form Twos and Fours in Doubling the Gait.....	71
To Break by Twos and by File in Doubling the Gait.....	72
Direct March of the Platoon in Line.....	73
Counter-march.....	74
Wheeling.....	75
To Wheel on Fixed Pivot.....	76
To Wheel on a Movable Pivot.....	83
Individual Oblique March.....	83
The Platoon March in Line, to Break it by Fours or by Twos at the same Gait.....	84
The Platoon Marching in Column by Twos or by Fours, to Form it at the same Gait.....	85
The Platoon Marching in Line, to break it by Fours or by Twos, in Doubling the Gait.....	86

	PAGE
The Platoon Marching in Column, by Twos or by Fours, to Form it in Doubling the Gait.....	86
Movements by Fours, the Platoon being in Column or in Line..	87
To Charge by Platoon.....	91
PART FIFTH—SCHOOL OF THE SQUADRON.....	92
Art. 1.—Preliminary Remarks.....	92
Successive Alignment of Platoons in the Squadron.....	93
Alignment of the Squadron.....	96
To Open and Close the Ranks.....	96
To Break the Squadron by Fours.....	97
Direct March in Column by Fours.....	97
Change of Direction, Individual Oblique March.....	98
The Squadron Marching in Column by Fours.....	98
To Form Front into Line.....	98
To Form to the Left into Line.....	100
To Form to the Right into Line.....	101
The Squadron being in Line, to Form it into Column with Distance.....	102
To March in column with Distance.....	102
Change of Direction by successive Wheels.....	103
Individual Oblique March.....	104
Change of Gait, Being in column with Distance.....	105
To Break by Fours, by Twos, and by File; to Form by Twos, Fours, and Platoons at the same Gait.....	105
To Break by Fours, by Twos, and by File; to Form Twos, Fours, and Platoons, in Doubling the Gait.....	108
The Squadron Marching in Column with Distance, To Face it in the Opposite Direction, and Face it again to the Front.....	110
To Halt the Column.....	111
To Form Line on the Left.....	111
To Break by the Right to March to the Left.....	112
To Form Line to the Right by Inversion.....	113
To Break to the Rear by the Right to March to the Left.....	114
To Form on Left into Line by Inversion.....	116
To Break by Platoons to the Front.....	117
To Form Front into Line.....	118
To Break by Platoons to the Right, and to Move Forward after the Wheel.....	119
To Form Line to the Front by Inversion.....	120
To Break by Platoons to the Right, Head of Column to the Left or Half Left.....	120
To Form Line Faced to the Rear, on the Rear of the Column....	121
To Form Line Faced to the Rear, by Inversion, of the Rear of the Column.....	122
To Break by Platoons to the Right; Head of the Column to the Right; (or Half Right).....	123
To Form Line Faced to the Rear on the Head of the Column....	124
To Form Line Faced to the Rear, by Inversion, on the Head to the Column.....	124

	PAGE
Movements by Fours, the Squadron being in Column with Distance.....	125
Direct March of the Squadron in Line.....	128
Counter-March.....	131
Wheeling.....	132
To Wheel on a Fixed Pivot.....	132
To Wheel on a Movable Pivot.....	135
Individual Oblique March.....	136
Oblique March by Platoons.....	137
Movements by Fours.....	138
The Squadron being in Line, to Cause it to Gain Ground to the Rear, and to Face it again to the Front.....	139
The Squadron Marching in Line, to Break it by Platoons to the Right, and to Form it again in Line.....	140
The Squadron Marching in Line, to March it to the Rear by Wheeling the Platoons about.....	141
The Squadron Marching in Line, to Break it to the Front by Platoons, and to Re-form it.....	142
The Squadron Marching in Line, to Break it to the Front by Platoons, in Doubling the Gait, and to Re-form it.....	143
Passage of Obstacles.....	145
Art. 4.—Charge.....	147
Rallying.....	151
Skirmishing.....	152
The Column by Divisions.....	156

CAVALRY DRILL.

PART FIRST.

INSTRUCTION ON FOOT.

ARTICLE FIRST.

Definitions and General Principles.

A TROOP is composed of ranks and files.

A RANK is composed of men abreast of each other.

A FILE is composed of two men, one behind the other.

FILE-LEADER is a man of the front rank of a troop, relatively to the one who is behind him in the rear rank.

FILE-CLOSER is an officer or Sergeant posted behind the rear rank.

FRONT is the direction perpendicular to the alignment of a troop and before it, either in column or in line.

CENTRE is the middle of a troop.

WINGS are the two grand divisions into which any body of men is divided, when in line.

FLANK is the right or left side of a column, or line.

INTERVAL is the vacant space between two troops, or between the fractions of a troop in line. It refers more particularly to the space which the squadrons of a regiment in line should preserve between each other.

This interval is twelve paces, (twelve yards,) measured

from the knees of the Sergeant (not counted in the rank) on the left of a squadron, to the knees of the Sergeant on the right of the squadron which follows in order of battle.

On foot, it is measured from the elbows of the same Sergeants.

DISTANCE is the vacant space from one troop to another in column, or between the ranks of a troop, either in line or in column.

The distance between the open ranks, when mounted, is six yards, measured from the croup of the horses of the front rank to the head of the horses of the rear rank; on foot, this distance is six paces.

When the ranks are closed, the distance, if mounted, is two feet, measured from the croup of the horses of the front rank to the head of those of the rear rank; on foot, it is one foot, measured from the breast of a man in the rear rank to the back of his file-leader.

When a troop is formed in column of platoons, or divisions, the distances prescribed are measured from the men of one front rank to those of another front rank; on foot, they are measured from the elbows of the men of one front rank to the elbows of the men of another front rank.

DEPTH is the space included between the head and the rear of a column.

The depth of a column of platoons is equal to the front which the troop occupied in line; it is measured from the head of the horse of the officer commanding the first platoon, to the croup of the horses of the file-closers of the last platoon.

To estimate the front of a troop, and the depth of a column, it is necessary to know that a horse, when mounted, occupies in breadth one-third of his length; this breadth is a little less than a yard. To avoid fractions, and arrive at the same result by a more simple calculation, having regard also to the room which the men must always preserve in the ranks, it is supposed to be one yard. The length of a horse being three

yards, the two ranks occupy six yards, with a distance of two feet between the ranks; a space which is necessary to prevent them from interfering on the march.

Taking the above dimensions for a base, the front of a squadron will consist of as many yards as there are files, plus the two Sergeants on the flanks. There will be a difference, however, according to the corps, and the manner in which the regiment is mounted; commandants of corps should satisfy themselves of it, by causing the front of their squadrons to be measured.

ALIGNMENT is the placing of men, or troops, on the same line. There are two kinds: *individual alignment*, and *alignment by troop*.

INDIVIDUAL ALIGNMENT is when men are placed abreast of each other, in a parallel direction, and without one being in front or in rear of another.

ALIGNMENT BY TROOP is when a troop places itself on the prolongation of a line already formed.

Every troop which is to form and align itself on another, halts on a line with the file-closers, parallel to the line of formation, to place itself afterwards on the alignment of the troop which is already formed.

The commandant of a troop places himself, to align it, on the side indicated by the command; it is the same if the troop which he commands serves as base of alignment to another troop. But the commander of a troop which aligns itself on another, moves on the opposite side to align it.

A **PLATOON** is composed habitually of twelve files; it may also be increased to sixteen; in that case, it is divided into two sections.

A **DIVISION** is composed of two platoons.

A **SQUADRON** is composed of two divisions, or four platoons.

A **REGIMENT IN ORDER OF BATTLE (OR LINE)** is composed of its squadrons disposed on the same line with their intervals.

It is in **NATURAL ORDER** when the squadrons are placed in the order of their numbers from right to left.

It is in **INVERSE ORDER** when the first squadrons are on the left of the line, and the last on the right, or when the subdivisions of each squadron are inverted. This order should be used only when circumstances require it.

A **COLUMN** is the disposition of a troop which has broken, and of which the fractions are placed one behind another.

There are three kinds of columns: *column in route*, *column with distance*, and *close column*.

COLUMN IN ROUTE is formed of men by twos, or by fours.

COLUMN WITH DISTANCE is formed of platoons, having between them the distance necessary to form in line in every way. This column may also be formed of divisions; but the proportion of a platoon front is the most advantageous for all movements.

CLOSE COLUMN is formed of squadrons with a distance of twelve yards from one to another; the object of this disposition is to give the least possible depth to the column.

The column has the *right in front* when its fractions are disposed according to the order of their numbers, from front to rear.

The column has the *left in front* when the last fractions, in the order of their numbers, are in front.

FIXED POINTS, or **POINTS OF DIRECTION**, serve to point out the direction in which a troop in line, or in column, is to march; or else to mark the right and left of a line.

INTERMEDIATE POINTS are those taken between the fixed points. They are used to preserve the desired direction during the march, or to insure the rectitude of the formation of the lines.

GENERAL GUIDES are the two Sergeants who, in the formation of a regiment, mark the points where the right and the left are to rest.

They are selected in the first and last squadrons, and are under the orders of the Adjutant and Sergeant-Major, for the tracing of lines.

PRINCIPAL GUIDES are the Sergeants who serve to mark the intermediate points in the formation in line.

The Sergeants, file closers of the 1st and 4th platoons, are the principal guides of their respective squadrons.

PARTICULAR GUIDES are the Sergeants who place themselves on the line of formation, to mark the front of their squadrons as they arrive.

The two Sergeants of the flanks, who are not counted in the rank, are the particular guides of their respective squadrons.

GUIDE OF THE MARCH IN LINE is the Sergeant file-closer of one of the wings, who, in the march in line, replaces the particular guide in the front rank, when the latter places himself on the alignment, to insure the direction of the march by serving as an intermediate point.

GUIDE OF THE COLUMN is the man on one of the flanks of the front rank of a column; he is charged with the direction of the march.

The guide is always left when the right is in front; the exceptions to this general rule are pointed out in the title of the evolutions.

In the oblique march the guide is on the side towards which the march is made; and when the primitive direction is resumed, after having obliqued, the guide is where it was before having obliqued.

In a column composed of cavalry and infantry, the guides of the cavalry cover the second file of the subdivisions of infantry on the side of the guides. In line, the officers who are in front of the squadrons, align themselves on the rear rank of the infantry.

WHEEL is a circular movement executed by a man or troop, returning to the point of departure.

When a troop makes a wheel, it turns upon one of its flanks; each of the men composing it describes a circle, larger in proportion to his distance from the central point.

ABOUT FACE, OR WHEEL, is the half of a wheel.

RIGHT OR LEFT FACE, OR WHEEL, is the fourth of a wheel.

RIGHT HALF, OR LEFT HALF FACE, OR WHEEL, is the eighth of a wheel.

RIGHT QUARTER, OR LEFT QUARTER FACE, OR WHEEL, is the sixteenth of a wheel.

Pivot is the front rank man of the flank on which the wheel is made. There are two kinds: the *fixed pivot*, and the *moveable pivot*.

The pivot is *fixed* whenever he turns upon himself; he is *moveable* when he describes an arc of a circle.

The arc of a circle described by the pivot of a rank of two, of four, of eight, or of a platoon, making the fourth of a wheel, is *five yards*; for a division it is *ten yards*; and for a squadron it is *twenty yards*.

PLOYMENT is the movement by which a regiment forms from line into close column.

DEPLOYMENT is the movement by which a regiment forms from close column into line.

FORMATION is the regular placing of all the fractions of a troop either in line or in column.

PACES. There are three kinds: the *walk*, the *trot*, and the *gallop*.

On foot there are two kinds of step: the *common step*, and the *quick step*.

When the command does not indicate the pace, the movement is always made at a walk, if the troop is halted; if it is marching, the movement is made at the pace at which it was already marching.

On foot, the movements are executed habitually at the *quick step*, without the command being given. When they are to be executed at the *common step* the command should signify it.

The pace, when used as a measure, is *three feet*. On foot it is *two feet four inches*.

A horse passes over about *one hundred yards per minute* at a walk, *two hundred and forty* at a trot, and *three hundred* at a gallop.

On foot the common step is at the rate of *ninety per minute*; the quick step is at the rate of *one hundred and twenty per minute*.

THE DIRECT MARCH is that which is executed by a troop in line or in column, to move off perpendicularly to its alignment.

THE MARCH BY A FLANK is that by which ground is gained to the right or left, after having made the fourth of a wheel.

THE DIAGONAL MARCH is thus called in relation to the front from which it commences by changing direction by the eighth of a wheel to the right or left, in order to arrive at a given point on the right or left.

THE OBLIQUE MARCH is that by which, when moving forward, ground is gained towards one of the flanks without changing the front. There are two kinds; the *individual oblique march*, and the *oblique march by troop*.

The *individual oblique march* is that which is executed by an individual movement of each man.

The *oblique march by troop* is that which is executed by the movement, at the same time, of each of the subdivisions of a troop in line.

THE CIRCULAR MARCH is that which is executed by describing a circle or portion of a circle.

COUNTER MARCH is a movement by which the men of each rank, after having made successively the fourth of a wheel to the right or left, form themselves facing the rear, parallel to the first formation.

THE CHARGE is a direct, quick and impetuous march, the object of which is to reach the enemy.

SKIRMISHERS (OR FLANKERS) are men dispersed in front, in rear, or on the flanks of a troop, to cover its movements or its position.

OBSTACLE is anything in the nature of the ground, which obliges a troop in line to ploy a part of its front.

DEFILE is a passage which compels a line to ploy into column, or a column to diminish its front.

EVOLUTIONS are the regular movements by which a regiment passes from one order to another.

EVOLUTIONS OF LINE are these same movements executed by several regiments, on one or several lines.

Their application, combined with the position or movements of the enemy, are called MANŒUVRES.

COMMANDS. There are three kinds :

The command of CAUTION, which is attention. It is the signal to preserve immobility, and to give attention.

The PREPARATORY COMMAND. It indicates the movement which is to be executed.

It is at this command that the horses are *gathered*.

The command of EXECUTION, which is *march* or *halt*.

The tone of command should be animated, distinct, and of a loudness proportioned to the troop which is commanded.

The command ATTENTION, is pronounced at the top of the voice, dwelling on the last syllable.

The commands of EXECUTION are pronounced in a firmer tone than the PREPARATORY commands.

The commands of caution and the preparatory commands, are distinguished by *italics* ; those of execution by CAPITALS.

Those preparatory commands which, from their length, are difficult to be pronounced at once, must be divided into two or three parts, with an ascending progression in the tone of command, but always in such a manner that the one of execution may be more energetic and elevated (*the divisions are indicated by a hyphen -*). The parts of commands which are placed in parenthesis are not pronounced.

TIME, in the detailed instruction, is an action of exercise which is executed at a command or part of command, and which is divided into *motions*, to demonstrate the mechanism and facilitate the execution of it.

SOUNDINGS are the trumpet signals, which make known to the troop the movements or details of service which are to be executed.

ARTICLE SECOND.

School of the Trooper Dismounted.

The preliminary instruction to be given to recruits for the mounted service, is the same as that given to the foot soldier, previous to his instruction in the manual of arms, embracing *the position of the soldier, the facings and marching*. All of which being fully described in the first part of Instruction in Infantry Tactics, need not be repeated here, as reference may be made to that book.

ARTICLE THIRD.

The Sabre Exercise.

This is taught to a squad of from eight to ten men, placed in one rank, nine feet from each other, having the sabre hooked up with the hilt to the rear.

The instructor commands:

DRAW—SABRE.

Two times.

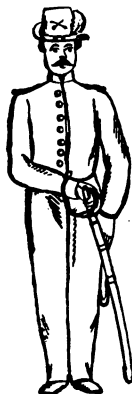

Fig. 1.

1. At the first part of the command, which is DRAW, turn the head slightly to the left, without deranging the position of the body; unhook the sabre with the left hand, and bring the hilt to the front; run the right wrist through the sword-knot; seize the gripe, draw the blade *six* inches out of the scabbard, pressing the scabbard against the thigh with the left hand, which seizes it at the upper ring, and turn the head to the front. Fig. 1.

2. At the last part of the command, which

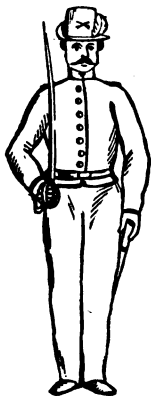

Fig. 2.

is **SABRE**, draw the sabre quickly, raising the arm to its full extent; make a slight pause, carry the blade to the right shoulder, the back of it against the hollow of the shoulder, the wrist resting against the hip, the little finger on the outside of the gripe. Fig. 2.

This position is the same when mounted, except that the wrist then naturally falls upon the thigh.

Present—SABRE.

One time.

At the last part of the command, which is **SABRE**, carry the sabre to the front, the arm half extended, the thumb opposite to, and *six* inches from the neck, the blade perpendicular, the edge to the left, the thumb extended on the right side of the gripe, the little finger by the side of the others. Fig. 3.

Carry—SABRE.

One time.

At the last part of the command, which is **SABRE**, carry the back of the blade against the hollow of the shoulder, the wrist resting against the hip, the little finger on the outside of the gripe. Fig. 2.

RETURN—SABRE.

Two times.

1. At the first part of the command, which is **RETURN**, execute the first motion of *present sabre*, Fig. 3.



Fig. 3.

2. At the last part of the command, which is **SABRE**, carry the wrist opposite to, and six inches from the left shoulder; lower the blade and pass it across and along the left arm, the point to the rear; turn the head slightly to the left, fixing the eyes on the opening of the scabbard; return the blade, free the wrist from the sword-knot, turn the head to the front, drop the right hand by the side, and hook up the sabre with the hilt to the rear.

Inspection—(of) SABRE.

One time and seven motions.

1. At the last part of the command, which is **SABRE**, execute the first time of *draw sabre*, Fig. 1.
2. Execute the second time of *draw sabre*, Fig. 2.
3. Present the sabre as it is prescribed, Fig. 3.
4. Turn the wrist inwards, to show the other side of the blade.
5. Carry the sabre to the shoulder. Fig. 2.
6. Execute the 1st time of *return sabre*. Fig. 3.
7. Execute the 2d time of *return sabre*.

When the men execute the inspection of arms correctly, to exercise them without the details, the instructor commands:

Inspection—(of) ARMS.

Each man, as the instructor passes before him, presents the sabre, and turns the wrist inwards to show the other side of the blade, 3d and 4th motions of *inspection of sabre*.

As soon as the instructor has passed by two files, the man who has been inspected carries the sabre to the shoulder, returns it, 5th, 6th, and 7th motions of *inspection of sabre*.

The troopers being at attention with drawn sabres at **carry**, the instructor commands:



Fig. 4.

hand. Fig. 4.

GUARD.

One time.

At the command GUARD, carry the right foot *two* feet from the left, the heels on the same line; place the left hand closed, *six* inches from the body, and as high as the elbow, the fingers towards the body, the little finger nearer than the thumb (*position of the bridle hand*); at the same time, place the right hand in tierce at the height of, and *three* inches from, the left hand, the thumb extended on the back of the gripe, the little finger by the side of the others, the point of the sabre inclined to the left, and *two* feet higher than the

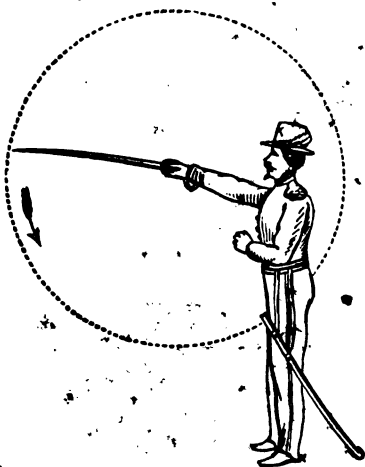

Fig. 5.

Left—MOULINET.

One time and two motions.

1. At the last part of the command, which is MOULINET, extend the right arm to the front to its full length, the hand in tierce and as high as the eyes.

2. Lower the blade in rear of the left elbow; graze the horse's neck quickly, describing a circle from rear to front, and return to the position of guard. Fig. 5.

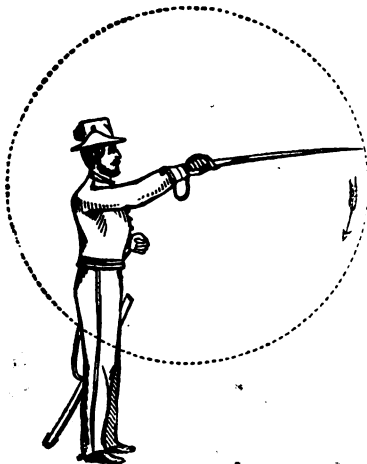

Fig. 6.

*Right—MOULINET.**One time and two motions.*

1. At the last part of the command, which is MOULINET, extend the right arm to the front to its full length, the hand in quarte, and as high as the eyes.

2. Lower the blade in rear of the right elbow; graze the horse's neck quickly, describing a circle from rear to front, and return to the position of guard.
Fig. 6.

To execute the moulinet without stopping, if the instructor wishes

to begin by the left, he commands :

*Left and Right—MOULINET.**One time and two motions.*

If he wishes to begin by the right, he commands :

*Right and Left—MOULINET.**One time and two motions.*

At either of these commands, the troopers, commencing from the position of GUARD, execute alternately what is laid down above, without stopping at any motion.

*Rear—MOULINET.**One time and two motions.*

Fig. 7.

several in succession, until the command **GUARD**.

1. At the last part of the command, which is **MOULINET**, raise the arm to the right and rear to its full extent, the point of the sabre upwards, the edge to the right, the thumb extended on the back of the gripe, the body slightly turned to the right.

2. Describe a circle in rear from left to right, the hand as far as possible from the body, and return to the position of guard. Fig. 7.

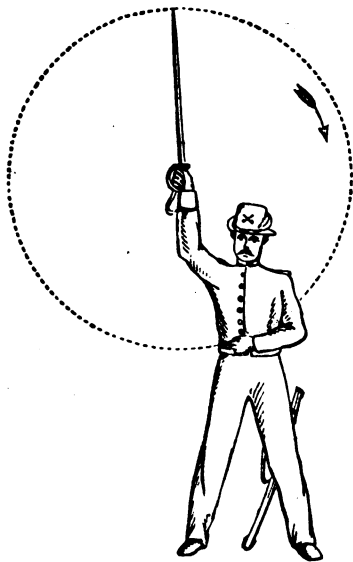
When the troopers execute the moulinets well, the instructor requires them to execute

*In tierce—POINT.**One time and three motions.*

1. At the last part of the command, which is **POINT**, raise the hand in tierce as high as the eyes, throw back the right shoulder, carrying the elbow to the rear, the point of the sabre to the front, the edge upwards. Fig. 8.

2. Thrust to the front, extending the arm to its full length.
3. Return to the position of guard.



Fig. 8.

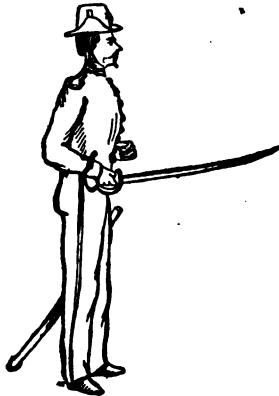

Fig. 9.

In quarte—POINT.

One time and three motions.

1. At the last part of the command, which is POINT, lower the hand in quarte near the right hip, the thumb extended on the right side of the gripe, the point a little higher than the wrist. Fig. 9.
2. Thrust to the front, extending the arm to its full length.
3. Return to the position of guard.

Left—POINT.

One time and three motions.

1. At the last part of the command, which is POINT, turn the head to the left, draw back the hand in tierce towards the right, at the height of the neck, the edge upwards, the point directed to the left. Fig. 10.

2. Thrust to the left, extending the arm to its full length
3. Return to the position of guard.



Fig. 10.

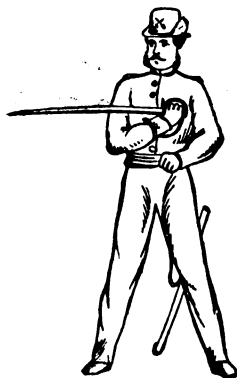

Fig. 11.

Right—POINT.

One time and three motions.

1. At the last part of the command, which is **POINT**, turn the head to the right, carry the hand in quarte near the left breast, the edge upwards, the point directed to the right. Fig. 11.



Fig. 12.

2. Thrust to the right, extending the arm to its full length.

3. Return to the position of guard.

Rear—POINT.

One time and three motions.

1. At the last part of the command, which is **POINT**, turn the head to the right and rear, bring the hand in quarte opposite to the right shoulder, the arm half extended, the blade horizontal, the point to the rear, the edge upwards. Fig. 12.

2. Thrust to the rear, extending the arm to its full length.
3. Return to the position of guard.

Against infantry left—POINT. One time and three motions.



Fig. 13.

1. At the last part of the command, which is POINT, turn the head to the left, raise the hand in tierce near the neck, the point of the sabre directed at the height of the breast of a man on foot. Fig. 13.

2. Thrust down in tierce.

3. Return to the position of guard.



Fig. 14.

Against infantry right—POINT.

One time and three motions.

1. At the last part of the command, which is POINT, turn the head to the right, carry the hand in quarte near the right hip, the point of the sabre directed at the height of the breast of a man on foot. Fig. 14.

2. Thrust in quarte.

3. Return to the position of guard.



Fig. 15.

Front—CUT.

One time and three motions.

1. At the last part of the command, which is CUT, raise the sabre, the arm half extended, the hand a little above

the head, the edge upward, the point to the rear and higher than the hand. Fig. 15.

2. Cut, extending the arm to its full length.
3. Return to the position of guard.

Left—Cut.

One time and three motions.



Fig. 17.

1. At the last part of the command, which is *CUT*, turn the head to the left, raise the sabre, the arm extended to the right, the hand in quarte, and as high as the head, the point higher than the hand. Fig. 16.

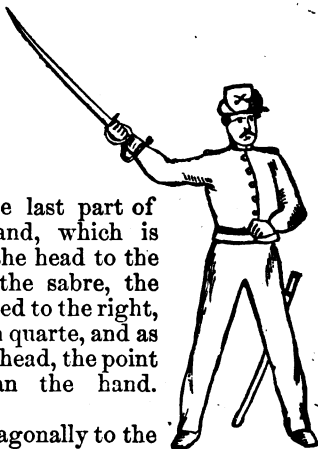

Fig. 16.

2. Cut diagonally to the left.
3. Return to the position of guard.

Right—Cut.

One time and three motions.

1. At the last part of the command, which is *CUT*, turn the head to the right, carry the hand opposite to the left shoulder, the point of the sabre upward, the edge to the left. Fig. 17.

2. Extend the arm quickly to its full length, give a back-handed cut horizontally.
3. Return to the position of guard.

These cuts are also used against infantry, observing to direct them vertically.

Rear—CUT.

One time and three motions.

1. At the last part of the command, which is *CUT*, turn the head to the right, throwing back the right shoulder; carry the hand as high as, and opposite to the left shoulder, the sabre perpendicular, the edge to the left. Fig. 18.

2. Extend the arm quickly to its full length, and give a back-handed cut horizontally, to the rear.

3. Return to the position of guard.



Fig. 18.

Right, in tierce and quarte—CUT.

One time and four motions.

1. At the last part of the command, which is *CUT*, execute the 1st motion of *right cut*.

2. Execute the 2d motion of *right cut*.

3. Turn the hand in quarte, and cut horizontally.

4. Return to the position of guard.

Left, in quarte and tierce—CUT.

One time and four motions.

1. At the last part of the command, which is *CUT*, execute the 1st motion of *left cut*.

2. Execute the 2d motion of *left cut*.

3. Turn the hand in tierce, and cut horizontally.

4. Return to the position of guard.

*Rear, in tierce and quarte—CUT.**One time and four motions.*

1. At the last part of the command, which is CUT, execute the 1st motion of *rear cut*.



Fig. 19.

2. Execute the 2d motion of *rear cut*.

3. Turn the hand in quarte, and cut horizontally.

4. Return to the position of guard.

*In tierce—PARRY.**One time and two motions.*

1. At the last part of the command, which is PARRY, carry the hand quickly a little to the front and right, the nails downward, without moving the elbow; the point inclined to the front, as high as the eyes, and in the direction of the right shoulder; the thumb extended on the back of the gripe, and pressing against the guard. Fig. 19.

2. Return to the position of guard.



Fig. 20.

*In quarte—PARRY.**One time and two motions.*

1. At the last part of the command, which is PARRY, turn the hand and carry it quickly to the front and left, the nails upward, the edge to the left, the point inclined to the front, as high as the eyes, and in the direction of the left shoulder; the thumb extended on the back of the gripe, and resting against the guard. Fig. 20.

2. Return to the position of guard.



Fig. 21.

For the head—PARRY.

One time and two motions.

1. At the last part of the command, which is PARRY, raise the sabre quickly above the head, the arm nearly extended, the edge upward, the point to the left, and about six inches higher than the hand. Fig. 21.

2. Return to the position of guard.

Against infantry right—PARRY.

One time and three motions.

1. At the last part of the command, which is PARRY, turn the head to the right, throwing back the right shoulder,

raise the sabre, the arm extended to the right and rear, the point upward; the hand in tierce, the thumb extended on the back of the gripe, the edge to the left. Fig. 22.

2. Describe a circle quickly on the right from rear to front, the arm extended; turn aside the bayonet with the back of the blade, bringing the hand as high as the head, the point upward.

3. Return to the position of guard.



Fig. 22.

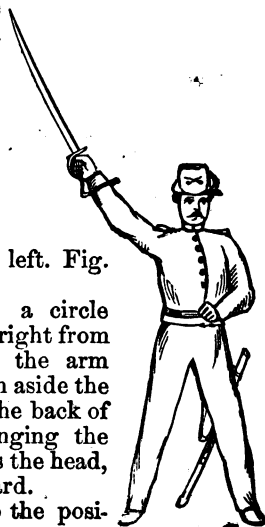

Fig. 22.

*Against infantry left—PARRY.**One time and three motions.*

1. At the last part of the command, which is PARRY, turn the head to the left, raise the sabre, the arm extended to the front and right, the point upward, the hand in tierce, the thumb extended on the back of the gripe, the back of the blade to the front. Fig. 23.

2. Describe a circle quickly on the left, from front to rear along the horse's neck, the arm extended; turn aside the bayonet with the back of the blade, bringing the hand, still in tierce, above the left shoulder.

3. Return to the position of guard.

When the troopers begin to execute correctly the above cuts, thrusts, and parries, the instructor requires them to make the application of them by combined motions, as follows :

In tierce—POINT AND FRONT CUT.

In quarte—POINT AND FRONT CUT.

Left—POINT AND CUT.

Right—POINT AND CUT.

Rear—POINT AND CUT.

Against infantry right—POINT AND CUT.

Against infantry left—POINT AND CUT.

CARRY—SABRE.

As it is prescribed, and carry the right foot by the side of the left.

Remarks.

The instructor explains what is meant by *right and left side of the gripe*; by *tierce* and by *quarte*.

The right side of the gripe is the side opposite to the guard.

The left side of the gripe is the side next to the guard.

Tierce is the position in which the edge of the blade is turned to the right, the nails downward.

Quarte is the position in which the edge of the blade is turned to the left, the nails upward.

The object of the *moulinet* is to render the joints of the arm and wrist supple, and as it adds to the confidence of the men when isolated, by increasing their dexterity, they should first be exercised at it, as a preparation for the other motions.

Each lesson is therefore commenced and ended with *moulinets*, executed with a quickness proportioned to the progress of the troopers. The instructor pays particular attention that the men do not employ a degree of force in the sabre exercise, which not only is less necessary than skill and suppleness, but which is even prejudicial. He observes, also, that they do not lean to one side, in such a manner as to lose the seat, when mounted; he requires more especially, in the motions of the sabre to the rear, that the blade shall not fall too near the body, for fear of wounding the horse. In describing a circle, the flat of the blade should be to the side, and the edge to the front, and it should be so directed as not to touch either the horse's head, or his haunches, or the knees of the rider.

When the troopers execute all the motions with regularity, the instructor requires each cut to be given without decomposing it; the last syllable of a command is the signal for the quick execution of it. All the cuts are then terminated by a half-*moulinet*, which brings back to the position of *GUARD*.

Thrusts should always be used in preference, as they require less force, and their result is more prompt, sure, and decisive. They should be directed quickly *home* to the body of the adversary, the sabre being held with the full grasp, the thumb pressing against the guard in the direction of the blade.

The instructor allows the men to rest frequently during the lesson, in which case he causes the sabre to be returned.

PART SECOND.

INSTRUCTION ON HORSEBACK.

ARTICLE FIRST.

To Conduct his Horse to the Ground.

The trooper conducts his horse to the ground, the reins passed over the neck, and their extremity engaged in the left cloak strap. He holds the reins with the right hand at *six* inches from the mouth of the horse, the nails under, the hand elevated and firm to prevent the horse from jumping.

When the trooper is under arms, he has the sabre hooked up.

Position of the Trooper before Mounting.



Fig. 24.

The trooper places himself on the left side of the horse, abreast of the nether jaw: he holds the reins with the right hand at *six* inches from the mouth of the horse, the nails downward.

The trooper has his heels upon the same line and as near together as his conformation will permit, the feet at little less than a right angle, and equally turned out; the knee straight without being stiff, the body perpendicular upon the haunches, and slightly inclined forward; the left hand hanging at the side, the palm a little turned out, the little finger along the seam of the pantaloons; the head erect.

without being constrained, the chin drawn into the neck without covering it, the eyes fixed to the front. Fig. 24.

When the trooper is under arms, he has the left hand over the sabre.

To Mount.

The instructor commands :

PREPARE TO MOUNT.

One time and two motions.

1. At the command PREPARE TO MOUNT, Nos. 1 and 3 of each rank move six paces to the front, stepping off with the left foot, keeping opposite their intervals, and regulating by the right.

Place the right foot three inches in rear of the left; make a face and a half to the right on both heels, the right foot remaining in front; let go the right rein; slip the right hand along the left rein; take two steps, stepping off with the right foot, and face to the left upon the point of the left foot, the right side toward the flank of the horse; carry back the right heel three inches in rear of the left; the right hand seizing the end of the reins is placed upon the cantle of the saddle.

2. Place a third of the left foot in the stirrup, supporting it against the fore-arm of the horse; rest upon the point of the right foot, and seize with the left hand over the reins a lock of the mane as far forward as possible, the extremity of the lock passing out of the hand on the side of the little finger.

MOUNT.

One time and two motions.

1. At the command MOUNT, spring from the right foot, holding firmly to the mane, at the same time pressing the cantle to prevent the saddle from turning; the body erect.

2. Pass the right leg stretched over the croup of the

horse, without touching him ; sit lightly in the saddle, placing at the same time the right hand, without quitting the reins, upon the right holster, the palm of the hand resting upon it, the fingers on the outside of it, and take one rein of the snaffle in each hand.

(If the trooper is using the curb-bridle, he will pass the reins of it in the left hand and adjust them.)

Place the right foot in the stirrup.

Form—RANKS.

At the last part of the command, which is RANKS, Nos. 1 and 3 raise the wrists (or the bridle hand), and hold the legs close to the body of the horse to keep him quiet ; Nos. 2 and 4 enter the intervals without jostling and without precipitation.

The rear rank being formed, closes to the distance of two feet from the front.

Remarks.

Before the causing the command MOUNT to be executed, the instructor explains in detail the two times of it, and allows but a short interval between the first and second part of this command, because, were the trooper to remain a long time on the stirrup, the horses would become restive and move out of their proper places.

The instructor will explain to the troopers, that in carrying the right hand to the holster before placing themselves in the saddle, they will be able to do so lightly, and will not run the risk of injuring themselves in bestriding their horses.

The instructor causes the stirrups to be crossed upon the neck, the left stirrup over the right.

Position of the Trooper Mounted.

The buttocks bearing equally upon the saddle, and as far forward as possible ;

The thighs turned upon their flat side without effort,

embracing equally the horse, and stretched only by their own weight and that of the legs ;

A supple bend of the knees ;

The legs free and falling naturally ;

The point of the feet falling in like manner ;

The loins supported without stiffness ;

The upper part of the body at ease, free and erect ;

The shoulders equally thrown back ;



Fig. 25.

The arms free, the elbows falling naturally ;

The head erect, at ease, and not drawn in between the shoulders ;

One rein of the snaffle in each hand, the fingers closed, the thumb along each rein, the wrists as high as the elbow, at six inches from each other, the fingers turned toward each other, the upper extremity of the reins leaving the hand on the side of the thumb. Fig. 25.

To Lengthen the Reins of the Snaffle.

The instructor commands :

Lengthen left (or right)—REIN.

One time and two motions.

1. At the last part of the command, which is **REIN**, bring the wrists toward each other without turning them in, seize the left rein with the thumb and first finger of the right hand, at *one* inch from the left thumb.

2. Half open the left hand, and allow the rein to slip until the thumbs touch; reclose the left hand, and replace the wrists.

To Shorten the Reins of the Snaffle.

The instructor commands :

Shorten left (or right)—REIN.

One time and two motions.

1. At the last part of the command, which is **REIN**, bring the wrists toward each other without turning them in, seize the left rein with the thumb and first finger of the right hand, so that the thumbs touch.

2. Half open the left hand, elevate the right hand, and suffer the rein to slip until the thumbs are *one* inch apart; reclose the left hand, and replace the wrists.

The right rein is lengthened and shortened on the same principles, but by inverse means.

To Cross the Reins in the Left Hand.

The instructor commands :

Cross reins—IN LEFT HAND.

One time.

At the last part of the command, which is **LEFT HAND**, turn in the left wrist, the nails downward, at the same

time bring the wrist opposite to the middle of the body, half open the left hand, place in it the part of the rein that was in the right; reclose the left hand and let the right fall to the side.

To Take the Reins in Both Hands.

The instructor commands :

Separate—REINS.

One time.

At the last part of the command, which is REINS, half open the left hand, seize with the right hand, the nails downward, the part of the right rein which is in the left hand, and replace the wrists *six* inches apart.

To Cross the Reins in the Right Hand.

The instructor commands :

Cross reins—IN RIGHT HAND.

One time.

This is executed in the same manner as *cross reins in left hand*, but by inverse means.

The Use of the Reins.

The reins serve to prepare the horse for the movement he is required to execute, to direct him and to stop him. Their action should be progressive, and in accordance with that of the legs.

When the trooper makes use of the reins, the arms should act with suppleness, and their movements ought to extend from the wrist to the shoulder.

The Use of the Legs.

The legs serve to urge the horse forward, to support him, and to aid him in turning to the right and to the

left. Whenever the trooper wishes his horse to move forward, he should close the legs by degrees behind the girths, causing their effect to correspond with the sensibility of the horse, taking care neither to open nor elevate the knees, of which the bend should be always pliant. The trooper relaxes the legs by degrees, as he closed them.

• The Effect of the Reins and Legs Combined.

In elevating a little the wrists, and closing the legs, the trooper "gathers his horse;" in elevating again the wrists, he slackens the pace; in repeating this movement of the wrists he stops the horse, or "reins back." The trooper ought to elevate the wrists without curving them, at the same time drawing them slightly towards the body.

In opening the right rein and closing the right leg, the trooper turns his horse to the right. To open the right rein, the right wrist is carried, without turning it, more or less to the right, according to the sensibility of the horse.

In opening the left rein, and closing the left leg, the trooper turns his horse to the left. To open the left rein, the left wrist is carried, without turning it, more or less to the left, according to the sensibility of the horse.

By lowering slightly the wrists, the horse is at liberty to move forward; the closing the legs determines the movement.

To March.

The instructor commands:

1. *Squad forward.* 2. **MARCH.**

At the command *Squad forward*, elevate slightly the wrists, and close the legs in order to "gather the horse."

At the command **MARCH**, lower slightly the wrists, and close the legs more or less, according to the sensibility of the horse. The horse having obeyed, replace the wrists and the legs by degrees.

To Halt.

After some steps, the instructor commands :

1. *Squad.* 2. **HALT.**

At the command *Squad*, the trooper gathers his horse, without slackening his pace.

At the command **HALT**, the trooper braces himself in the saddle; elevate the wrists at the same time by degrees, and close the legs in order to prevent the horse from receding. The horse having obeyed, replace the wrists and the legs by degrees.

When the horse does not obey, cause him to feel successively the effect of each rein, according to his sensibility.

To Turn to the Right, and to the Left.

The instructor commands :

1. *Squad to the right (or to the left).* 2. **MARCH.** 3. **HALT.**

At the command *Squad to the right*, gather the horse.

At the command **MARCH**, open the right rein, and close progressively the right leg. In order not to turn the horse too short, perform the movement upon a quarter of a circle of *three* paces. The movement being almost completed, diminish the effect of the rein and the right leg, supporting the horse at the same time with the left rein and leg to terminate the movement.

At the command **HALT**, elevate slightly the wrists, and hold the legs near, in order to keep the horse straight in the new direction; replace the wrists and the legs by degrees.

To Turn-about to the Right, and to the Left.

The instructor commands :

1. *Squad to the right-about (or to the left-about).*
2. **MARCH.** 3. **HALT.**

This movement is executed on the principles prescribed

for the *turn to the right* or to the *left*, with this difference, that the horse should pass over a semicircle of *six* paces, and face to the rear.

To make a Quarter-turn to the Right and to the Left.

The instructor commands :

1. *Squad right oblique* (or *left oblique*).
2. MARCH. 3. HALT.

At the command *Squad right oblique*, gather the horse.

At the command MARCH, open a little the right rein, and close slightly the right leg, in order to make the horse execute a *quarter-turn to the right*; cause the horse to feel, almost at the same time, the effect of the rein and the left leg, to terminate the movement without increasing the degree of obliquity.

At the command HALT, elevate slightly the wrists and close the legs, to keep the direction of the *quarter-turn to the right*; replace the wrists and the legs by degrees.

To Rein-back, and to Cease Reining-back.

The instructor commands :

1. *Squad—Backwards*. 2. MARCH. 3. *Squad*. 4. HALT.

At the command *Squad backwards*, gather the horse.

At the command MARCH, keep a firm seat, elevate the wrists, and close the legs. As soon as the horse obeys, lower and elevate successively the wrists, which is called *yielding and checking*. If the horse throws the haunches to the right, close the right leg; if he throws them to the left, close the left leg. If these means are not sufficient to replace the horse in his proper position, open the rein on the side towards which the horse throws his haunches, causing him to feel, at the same time, slightly, the effect of the opposite rein.

At the command *Squad*, the trooper prepares to stop.

At the command HALT, lower the wrists and close the legs. The horse having obeyed, replace the wrists and the legs by degrees.

To Dismount.

The instructor causes the stirrups to be let down and the feet put in them. He then commands:

1. PREPARE TO DISMOUNT.

One time and two motions.

1. *At the command PREPARE TO DISMOUNT, Nos. 1 and 3 of the front rank move forward six paces, Nos. 2 and 4 of the rear rank rein-back four paces, and keep themselves opposite their intervals. The troopers of each rank dress by the right. Pass the right rein of the snaffle into the left hand, the extremity of the reins leaving the hand on the side of the thumb.*

DISMOUNT.

One time and two motions.

1. *At the command DISMOUNT, rise upon the left stirrup; pass the right leg extended over the croup of the horse, without touching him, and bring the right thigh near to the left, the body being well sustained; place at the same time the right hand upon the cantle of the saddle, slipping it along the reins without letting them go; descend lightly to the ground, the body erect, the heels upon the same line. Let go the mane with the left hand; engage the extremity of the reins in the left cloak-strap with the right hand, which then seizes the left rein.*

2. *Make a face and two steps to the left, stepping off with the left foot; slip the right hand along the left rein, seize with the same hand both reins at six inches from the mouth of the horse, the nails downward, and take the position of the trooper before mounting.*

Form—RANKS.

At the last part of the command, which is RANKS; Nos. 1 and 3 of each rank elevate slightly the right hand to keep

the horse quiet: Nos. 2 and 4 return to their intervals gently.

Length of the Stirrups.

They are of the proper length if, when the trooper raises himself on the stirrups, there is a space of six inches between the fork and the saddle.



Fig. 26.

Position of the Foot in the Stirrup.

The stirrup should support only the weight of the leg; the foot ought to be inserted one-third of its length, the heel lower than the toe. Fig. 26.

The stirrup should support only the weight of the leg: if the trooper bore too much upon the stirrups, his seat would be deranged as well as the position of the legs, and the justness of their action would be impaired.

The foot ought to be inserted one-third of its length: if the trooper did not insert the foot sufficiently far in the stirrup, he would risk losing them, particularly during the lively gaits. If the foot were inserted too far, the legs would not fall naturally.

The heel lower than the toe: that the foot may keep the stirrup without effort and without stiffness; that the play of the joint with the leg may remain free, and that the spur being further removed from the horse, there is less danger of its being improperly employed.

Position of the Bridle-Hand with Curb.

The reins with their slide in the left hand, the little finger between the reins, the other fingers well closed, and the thumb upon the second joint of the first finger; the elbow slightly detached from the body, the hand *four* inches above the pommel of the saddle, the fingers *six* inches from, and turned toward the body; the little finger a little nearer the body than the upper part of the wrist, the right hand at the side. Fig. 26.

The Principal Movements of the Bridle-Hand.

In raising slightly the hand and drawing it in toward the body, the trooper gathers his horse; in raising it still more, the gait is made slower. By increasing the effect of the hand, the horse is stopped; if increased still more, the horse is reined back.

In lowering slightly the hand, the horse is at liberty to move forward.

In carrying the hand forward and to the right, the horse is turned to the right.

In carrying the hand forward and to the left, the horse is turned to the left.

As soon as the horse obeys, the bridle-hand resumes its original position.

In all the movements of the hand, the arm should act freely, without communicating constraint to the shoulder or body; the effect of the curb being more powerful than that of the snaffle, it should be used progressively.

ARTICLE SECOND.

Manual for Colt's Revolver.

The trooper being mounted, holding the reins as prescribed, the pistol either in the holster or pistol-case, the instructor will command:

DRAW—PISTOL.

Two times.

1. At the first command, unbuckle the holster or pistol-case, seize the pistol by the handle with the right hand, holding it between the palm of the hand and the three last fingers, the fore-finger resting on the guard, the thumb on the handle.

2. At the second command, draw out the pistol and elevate it, the guard to the front, the wrist at the height of, and six inches from the right shoulder.

Load in six times.

1. LOAD.

One time and one motion.

Place the pistol in the bridle-hand, holding it by the handle in front of the body, the hammer between the thumb and fore-finger, and turned to the left, the muzzle pointing upward. Carry the right hand to the cartridge-box and open it.

2. HANDLE—CARTRIDGE.

One time and one motion.

Seize the cartridge with the thumb and the first two fingers, and carry it to the mouth.

3. TEAR—CARTRIDGE.

Bite off the end and carry the cartridge opposite the chamber nearest the lever.

4. CHARGE—CARTRIDGE.

One time and two motions.

1. Empty the powder into the chamber and insert the ball, pressing it down as far as possible with the thumb and fore finger.

2. Turn the pistol with the left hand, bringing the hammer toward the body, and cock it with the thumb of the right hand.

5. RAM—CARTRIDGE.

One time and two motions.

1. Seize the lever at the catch with the thumb and fore finger of the right hand, ram down the ball and replace the lever.

2. Let down the hammer with the right hand, and carry the hand to the cartridge-box.

Repeat as above until all the chambers are loaded.

6. PRIME.

One time and two motions.

1. Lower the muzzle toward the right side by turning the wrist of the bridle-hand, the muzzle pointing downward, the hammer to the front, the left wrist resting against the stomach; half-cock the pistol with the left thumb, turn the cylinder with the thumb and fore-finger of the right hand until it clicks. Take a cap and press it on the exposed cone. Turn again the cylinder until it clicks, and so on until all the cones are capped, the hammer resting on the safety notch.

2. Seize the pistol at the handle with the right hand, and bring it to the position of *draw pistol*.

The instructor wishing to fire, will command :

READY.

One time and two motions.

1. Place the pistol in the left hand, the little finger touching the key, the barrel nearly vertical, the muzzle

a little inclined to the left and front, the guard to the front, the thumb on the head of the hammer, the fore-finger along the guard.

2. Cock the pistol, and bring it to the position of *draw pistol*.

AIM.

One time.

Lower the pistol, the arm half extended, and place the fore finger lightly on the trigger, the muzzle directed to the height of a man's waist.

FIRE.

One time.

Press the fore finger steadily on the trigger, fire, and retake the position of *draw pistol*.

The men being at a ready, and the instructor wishing to fire all the barrels in quick succession, will give an intimation to that effect, and then command :

1. AIM. 2. FIRE.

The men will aim and fire, come to the first position of ready, cock, aim, and fire again, and so continue until the pistol is discharged ; then take the position of *draw pistol*.

The instructor wishing to reload, will command :

LOAD AT WILL.

LOAD.

2.

One time.

Load the six chambers as heretofore prescribed, and take the position of *draw pistol*.

RETURN PISTOL.

One time.

Lower the muzzle of the pistol, and return it to the holster or pistol-case.

When the troopers become well instructed in the use of the pistol, the following mode of coming to a ready will be substituted for the above :

READY.









Incline the muzzle of the pistol to the front, the wrist remaining six inches from the shoulder ; place the first joint of the thumb on the head of the hammer, and cock it by an extension of the thumb, and resume the position of *draw pistol*.

END OF SCHOOL OF THE TROOPER.

PART THIRD.

BASIS OF INSTRUCTION.

Explanation of Signs.

- C  C Captain Commanding.
 S  C Second Captain.
 L  — Lieutenant.
 S  L Second Lieutenant.
 S  — Sergeant.
 B  — Bugler.
 C  — Corporal.
 — Men of Front Rank.
 — Men of Rear Rank.

The rank of the several *sergeants* is designated by *figures* placed with the signs.

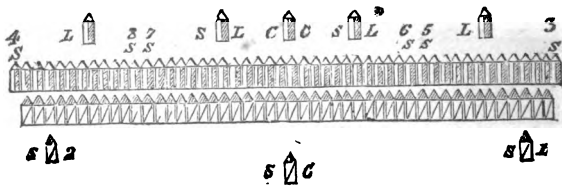

Fig. 27.

Posts of the Officers and Non-Commissioned Officers of a Squadron in line.—(Fig. 27.)

The Captain commanding is posted at the centre of the squadron, the croup of his horse one pace in front of the heads of the horses of the front rank.

The 2d Captain three paces in rear of the centre of the squadron. He is charged with the alignment of the rear rank and file closers.

The senior 1st Lieutenant commands the first platoon, the other 1st Lieutenant commands the fourth platoon.

The senior 2d Lieutenant commands the 2d Platoon; the other 2d Lieutenant commands the third platoon.

Each of these officers is posted at the centre of his platoon, with the croup of his horse one pace in front of the heads of the horses of the front rank.

The senior Sergeant is posted behind the third file from the right of the first platoon; he is the principal guide when the column of squadrons is left in front.

The 2d Sergeant behind the third file from the left of the fourth platoon; he is principal guide when the column of squadrons is right in front.

The third Sergeant is posted on the right of the front rank of the squadron; he is not counted in the rank.

The 4th Sergeant on the left of the front rank; he is not counted in the rank.

The 5th Sergeant on the left of the first platoon.

The 6th Sergeant on the right of the second platoon.

The 7th Sergeant on the right of the third platoon.

The 8th Sergeant on the right of the fourth platoon.

The heads of the horses of all the file closers are at one pace from the croup of those of the rear rank.

The corporals are posted in the front rank on the right and left of their respective platoons, and supply the places of the Sergeants when necessary.

When guidons are used, they are carried by the non-commissioned officers on the left of the first and third platoons.

*Posts of the Officers of a Squadron in Order of Column.
In column of fours and twos. (Fig. 28.)*

The Captain commanding marches on the side of the guides, and *four* paces from the flank, and abreast of the centre of their squadrons.

The second Captain marches on the side opposite to the guides, *four* paces from the flank, and abreast of the centre of their squadrons.

The Senior 1st Lieutenant of the squadron marches at the head of the 1st platoon, *one* pace in advance of the first files, having the particular guide of the right on his right.

The chiefs of the other platoons march on the side of the guides, *one* pace from the flank of the column, and abreast of their first files; the file-closers march on the side opposite to the guides, *one* pace from the flank, and on a line with the centre of their platoons.

They all march in a similar manner on the flanks of the column when the left is in front; and, in this case, it is the junior 1st Lieutenant who marches in the column at the head of the 4th platoon of the squadron.

The particular guide, who in line is posted on the left of the squadron, marches behind the last files of the squadron; when the column is left in front, he takes post on the left of the officer commanding the 4th platoon, *one* pace in front of the left file.

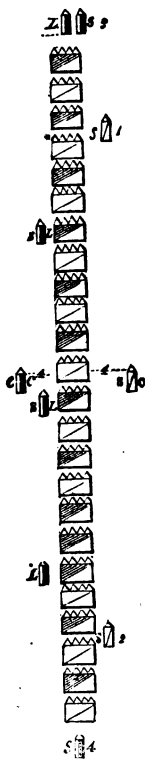

Fig. 28.

When the nature of the ground obliges the officers and file-closers to enter the column, the movement is made successively; the Captain commanding, and the

chiefs of platoons, place themselves at the head; the second Captain and the file-closers, in rear of their respective troops.

The primitive order is resumed as soon as the nature of the ground will permit.

In column of Platoons. (Fig. 29.)

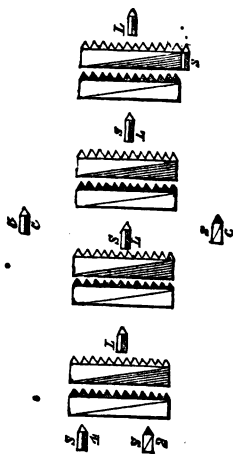

Fig. 29.

In this order, the distance from one platoon to another, measured from the men of one front rank to those of another front rank, is equal to the front of a platoon; that is to say, it is *twelve* paces if the platoons are of *twelve* files. Subtracting the depth of two ranks, which is *six* paces, there remains *six* paces from the croup of the horses of the rear rank of one platoon, to the heads of the horses of the front rank of the next platoon, a distance which is equal to half of the front of a platoon.

The Captain commanding marches on the side of the guides, *four* paces from the flank of the column, and habitually abreast

of the centre of the squadron.

The second Captain marches on the side opposite to the guides, *four* paces from the flank of the column, and abreast of the centre of the squadron.

The 1st and 2d Lieutenants march at the centre of their platoons, *one* pace from the front rank; when forming part of a regiment, those who command the platoons at the head of squadrons, preserve, besides their distance, the ground necessary to enable each squadron, in wheeling into line, to maintain its interval.

The Sergeants, who are file-closers, march on the side opposite to the guides, behind the third file of their platoons.

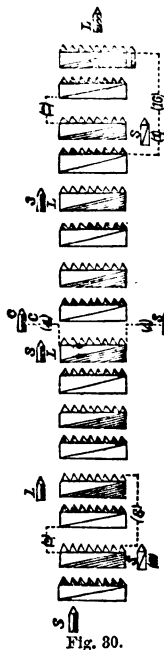

When the column marches right in front, the particular guide of the right of the squadron marches on the right of the 1st platoon; and the particular guide of the left places himself as file-closer behind the 2d file from the left of the 4th platoon.

The posts of these Sergeants is the reverse when the left is in front.

In column of Sections. (Fig. 30.)

The squadron being composed of sixty-four files, when it is broken into sections, the 1st Lieutenant of the squadron marches at the head of the 1st section of the 1st platoon; the chiefs of the other platoons remain on the side of the guides, one pace from and on a line with the front rank of their 1st section.

The file-closers who command the 2d sections, march on the side opposite to the guides, one pace from and on a line with the front rank.

The posts of the commandants of sections is the reverse when the left is in front.

In column of Divisions.
(Fig. 31.)

The Captain commanding, and the second Captain, are posted as in column of platoons.

The senior 1st Lieutenant commands the 1st division, the other 1st Lieutenant the 2d; they remain, however, at the centre of their platoons.

All the other officers and Sergeants of each di-

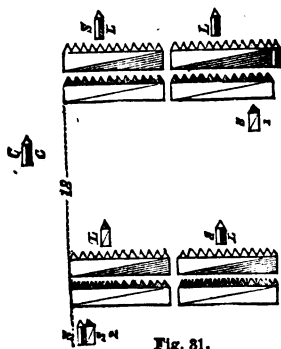

vision are posted as prescribed in the order in column of platoons, the file-closers remaining in their places, on whatsoever side the guide may be.

Posts of Officers and Non-Commissioned Officers of a Company acting singly.

The Captain in front of the centre, *one* pace distant from the front rank.

The 1st Lieutenant in rear of the centre, in the rank of file-closers.

The 2d Lieutenant commands the 1st platoon; in the absence of a 3d Lieutenant, the 2d platoon is commanded by the senior Sergeant. The chiefs of platoons are posted *one* pace in front of the centre of their respective platoons.

The first Sergeant in rear of the right, in the rank of file-closers.

The 2d and 3d Sergeants on the right and left of the troop, not told off.

A non-commissioned officer is posted on the left of the 1st platoon, and on the right of the 2d.

Corporals, next to the Sergeants who are on the flanks of platoons.

The Saddler and Farrier in rear of the left of the troop *eight* paces retired from the line of file-closers; and the Buglers *twenty* paces in rear of the centre.

PART FOURTH.

SCHOOL OF THE PLATOON.

Preliminary Remarks.

The troopers being sufficiently instructed to manage their horses and use their arms, are passed to the *school of the platoon*, the object of which is to teach them to exercise properly together, and execute all the movements of the platoon in the squadron, whether in column or in line.

Each movement, after having been correctly executed by the right, is repeated by the left, following the same principles, but by inverse means; the commands being the same, except the substitution of LEFT for RIGHT, and the reverse.

When the movements are all executed *at the walk*, the instructor causes them to be repeated *at the trot*, requiring always the same simultaneous action and the same precision. This gradation is also followed for the exercise *at the gallop*; but the horses are not kept a long time at this gait.

The platoon is composed of *twenty-four* or *thirty-two* men (*twelve* or *sixteen* files), including the Corporals, placed in the squadron in line; a non-commissioned officer is placed as file-closer; another non-commissioned officer is charged with aiding the instructor; he is termed assistant instructor.

When the platoon is broken in order to march in column, the assistant instructor, at the preparatory command, places himself at *one* pace in front of the first files. In all the formations and marches in line, he places himself at *one* pace in front of the centre of the platoon, the post of the chief of the platoon; the instructor moves wherever his presence is most required.

The platoon is formed in two ranks, at open order, the troopers and file-closers at the head of their horses, the assistant instructor mounted, facing the platoon, at *ten* paces from, and opposite the centre; the instructor commands :

1. ATTENTION. 2. *Right*—DRESS. 3. FRONT.

He then commands :

In each rank—COUNT (BY) FOURS.

Which is executed, commencing by the right.

The troopers then mount by the *times*, and without explanation.

At the command *Form*—RANKS, the assistant instructor moves forward, turns to the right-about, and places himself at the centre of the platoon, the croup of his horse *one* pace from the head of the horses of the front rank. The file-closer follows the rear rank.

General Principles of Alignment.

The troopers, to align themselves, should regulate their shoulders upon those of the men on the side of the alignment, and fix the eyes upon the line of the eyes, so as to perceive the breast of the second trooper of their rank on the side of the alignment; for this purpose, they should turn the head, remaining square upon their horses, feel lightly the boot of the man on the side of the alignment, and keep the horses straight in the ranks, that all may have a parallel direction.

The troopers of the rear rank, independently of the alignment, should be exactly behind their file-leaders, and in the same-direction, taking care to preserve the distance of *two* feet from head to croup.

Successive Alignment of Files in the Platoon.

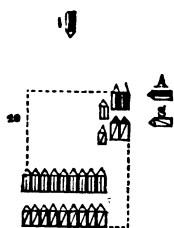

Fig. 32.

The two files of the right or of the left are moved forward *ten* paces, and aligned parallel to the platoon by the commands: 1. *Two files from right (or left) forward*; 2. MARCH; 3. HALT; 4. *Right (or left)—DRESS*; 5. FRONT. The instructor then commands:

1. *By file right (or left)—DRESS.*
2. FRONT.

Figure 32. At the last part of the first command, which is DRESS, each file moves forward successively and steadily, the troopers turning the head to the right and taking the last steps slowly, in order to arrive abreast of the files already formed without passing beyond the alignment, observing then to halt, give the hand, relax the legs, and keep the head to the right until the command FRONT.

Each file executes the same movement when the preceding one has arrived on the base of alignment, so that only one file may align itself at the same time.

At the command FRONT, turn the head to the front.

The instructor gives the command FRONT when the last file is aligned.

Figure 33. When the troopers execute correctly these alignments, this instruction is repeated in giving the two files of the right an oblique direction. For this purpose, the two files having marched forward *four* paces, as has been prescribed, execute a *half-turn to the right, or to the left*, and march *six* paces in this new direction.



Fig. 33.

The platoon being unmasked, the remainder of the movement is executed by the commands and following the principles prescribed above; each file as it arrives nearly opposite the place it is to occupy, executes a *half-turn to the right*, or *to the left*, so that having left the platoon by one straight line, it arrives upon the new alignment by another.

The two files of the right or of the left, are made to rein back *four paces*, and align themselves parallel to the platoon and opposite the place they occupied in it, by the commands: 1. *Two files from the right (or left) backwards*; 2. **MARCH**; 3. **HALT**; 4. *Right (or left)*—**DRESS**; 5. **FRONT**. The instructor then commands:

1. *By file—right (or left) backwards*—**DRESS**. 2. **FRONT**

Figure 34. At the last part of the first command, which is **DRESS**, each file reins back successively, keeping perfectly straight, the troopers turning the head to the right, and passing a little to the rear of the files already formed, in order to come up abreast of them by a movement to the front which renders the alignment more easy.

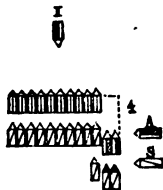

Fig. 34.

The troopers of the front rank rein back slowly, those of the rear rank regulate themselves upon their file leaders, preserving always their proper distance.

At the command **FRONT**, turn the head to the front.

The alignment is then executed by twos (or by fours). For this purpose the two or four files of the right move forward as has been prescribed, and the instructor commands:

1. *By twos (or by fours)—right (or left)*—**DRESS**.
2. **FRONT**.

At the last part of the first command, which is **DRESS**, the files align themselves successively by twos (or by

fours), following the principles prescribed for the alignment by file, being particular to set out and arrive upon the alignment together.

At the command **FRONT**, turn the head to the front.

Alignment of the Platoon.

The platoon being in line, the instructor places the Corporal of the flank on which he wishes to align it in such a position that no trooper will be forced to rein back, and commands:

1. *Right* (or *left*)—**DRESS**.
2. **FRONT**.

At the last part of the first command, which is **DRESS**, all the troopers align themselves promptly, but with steadiness.

At the command **FRONT**, turn the head to the front.

In all the alignments, the Corporal of the opposite flank aligns himself promptly on the one toward the side of the alignment, without respect to the individual alignment of the troopers.

To Open and Close the Ranks.

To open the ranks the instructor commands:

1. *Rear rank open order*.
2. **MARCH**.
3. *Right*—**DRESS**.
4. **FRONT**.

Figure 35. At the command **MARCH**, the front rank remains immovable, the rear rank reins back *six* paces, each trooper preserving the direction of his file-leader. The file-closer reins back until he is *six* paces from the rear rank. The assistant instructor moves forward *six* paces, and faces the platoon by a *turn-about to the left*.

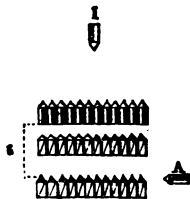

Fig. 35.

At the command *Right*—**DRESS**, the rear rank dresses to the right.

At the command **FRONT**, turn the head to the front.

To close the rank the instructor commands :

1. *Rear rank close order.* 2. MARCH. 3. *Right—DRESS.*
4. FRONT.

Figure 36. At the command MARCH, the rear rank

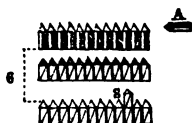

Fig. 36.

closes upon the front to the distance of *two feet*, each trooper taking care to preserve the direction of his file-leader. The assistant instructor resumes his place at the centre of the platoon, by a *turn-about to the right*, and the file-closer takes his proper distance from the rear rank.

At the command *Right—DRESS*, the platoon is aligned to the right.

To Rein Back the Platoon.

The platoon being halted, the instructor commands:

1. *Platoon backwards.* 2. *Guide right* (or *left*). 3. MARCH.

At the command MARCH, all the troopers rein back at once, regulating their movements by those of the guide.

When the platoon has reined back some steps, the instructor commands:

1. *Platoon.* 2. HALT. 3. *Right* (or *left*)—DRESS. 4. FRONT.

To Break the Platoon by File.

The platoon being in line the instructor commands:

1. *By file.* 2. MARCH.

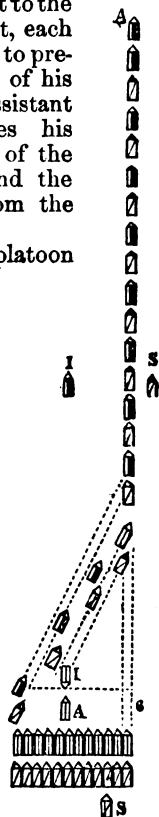

Fig. 37.

Figure 37. At the command *by file*, the troopers of the first file *gather* their horses, and the others successively, as soon as the file on the right is in motion.

At the command MARCH, the first file of the right moves straight to the front; it is followed by the other file; each file moves off when the haunches of the rear rank horse of the file which has broken, arrives at the head of the horses of the front rank; each file marches *six* paces straight to the front, makes a *quarter-turn to the right*, and marches in the new direction until it reaches its place in the column, when it makes a *quarter-turn to the left*.

Direct March in Column by File.

The troopers should keep their horses straight, and march at a free and equal gait; they should keep their eyes to the front and continue in the direction of the column, so as to perceive only the trooper who marches before them, to march at the same gait with him, preserving always the distance of two feet from head to croup, that his own horse may not tread upon the heels of the horse in front. This distance should be recovered gradually when lost.

To Halt, and to Commence the March in Column.

The column marching, to halt it the instructor commands:

1. *Column.* 2. HALT.

At the command HALT, the troopers stop together in the direction of their file-leaders and at their distances, taking care to prevent their horses from stepping back.

To move off, the instructor commands:

1. *Column forward.* 2. MARCH.

At the command MARCH, the troopers move off steadily together.

The column being at a halt, if the instructor wishes it to commence the move *at a trot*, he will command:

1. *Column forward—trot.* 2. MARCH.

In this case the assistant-instructor moves off promptly *at the trot*, that the troopers in his rear may take this gait at once, without marching first *at a walk*.

To halt the column marching *at the trot*, the instructor commands:

1. *Column.* 2. HALT.**Individual Oblique March.**

The column marching by file, the instructor commands.

1. *Left (or right) oblique.* 2. MARCH.

At the command MARCH, each trooper executes a *quarter-turn to the left*, and moves forward in his new direction, all following parallel lines, and regulating themselves toward the right, in order to keep on the same line, and to preserve their distances on that side.

To return to the primitive direction, the instructor commands:

FORWARD.

At this command the troopers return to the original direction, by a *quarter-turn to the right*, in advancing, and move forward in the direction of their file-leaders.

The Platoon Marching in Column by File, to Form it to the Front, to the Left, or on Right, into Line.*To Form Front into Line.*

The column marching right in front, to form it to the front into line, the instructor commands:

1. *Front into line.* 2. MARCH. 3. HALT.
4. *Right—DRESS.* 5. FRONT.

Fig 38. At the command MARCH, the first file continues to march straight forward. The others oblique immediately to the left, march in this new di-

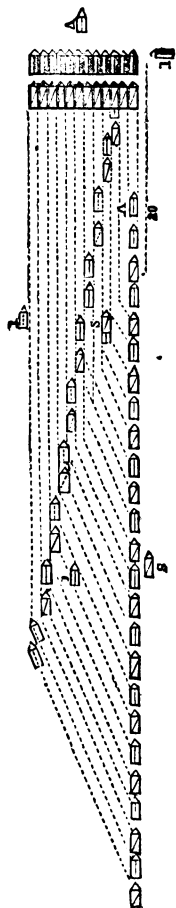

Fig. 83.

rection, and each file makes a *quarter-turn to the right* on coming opposite the place he is to occupy in the platoon.

When the first file has marched *twenty paces*, the instructor commands **HALT**. At this command, it halts square to the front; the other files come up and form successively on the left of the first, and dress to the right.

At the command **FRONT**, turn the head to the front.

The instructor gives the command *Right*—**DRESS** immediately after **HALT**, and commands **FRONT** when the last file is aligned.

To Form to the Left into Line.

The column marching right in front, to form it into line upon its left flank, the instructor commands :

1. *Left into line.* 2. **MARCH.** 3. **HALT.**
4. *Right—DRESS.* 5. **FRONT.**

At the command **MARCH**, the first file turns to the left and moves straight forward; the other files continue to march on, and at *two paces* before arriving opposite the place they are to occupy in the platoon, they turn successively to the left.

When the first file has marched *twenty paces*, the instructor commands **HALT**. At this command it halts; the other files come up and form successively on the left of the first, and dress to the right.

At the command **FRONT**, turn the head to the front.

The instructor gives the command *Right*—DRESS immediately after HALT, and commands FRONT when the last file is aligned.

To Form on Right into Line.

The column marching right in front, to form in line upon the prolongation and in advance of its right flank, the instructor commands :

1. *On right into line.* 2. MARCH. 3. HALT.
4. *Right*—DRESS. 5. FRONT.

At the command MARCH, the first file turns to the right and moves straight forward; the other files continue to march on, and each turns successively to the right at *one* pace beyond the point where the one preceding turned.

When the first file has marched *twenty* paces, the instructor commands HALT. At this command it halts; the other files come up and form successively on the left of the first, and dress to the right.

At the command FRONT, turn the head to the front.

The instructor gives the command *Right*—DRESS immediately after HALT, and commands FRONT when the last file is aligned.

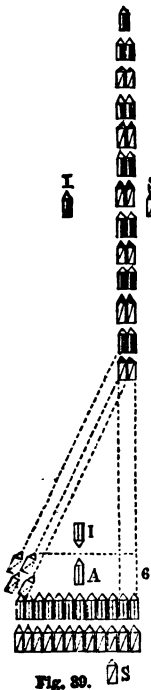

Fig. 39.

To Break the Platoon by Twos or by Fours.

The platoon being in line, the instructor commands :

1. *By twos* (or *by fours*). 2. MARCH.
3. *Guide left.*

Figs. 39 and 40. At the command MARCH, the first two or four files of the right move straight to the front; they

are followed by the other files, who move off when the haunches of the horses of the rear rank are on a line with the heads of the horses of the front rank. These files march straight forward *six* paces, execute a *quarter-turn to the right* by trooper, and march in this direction until they meet the column, when they take their places in it by making a *quarter-turn to the left*.

The command *guide left* is given immediately after that of **MARCH**, that the trooper on the left of the front rank of twos or fours, who becomes guide of the column, may take at once a point of direction.

After breaking by twos, Nos. *two* and *four* being guides, keep their eyes to the front. After reaching the column, Nos. *one* and *three* dress upon them.

After breaking by fours, Nos. *four* become guides of each rank.

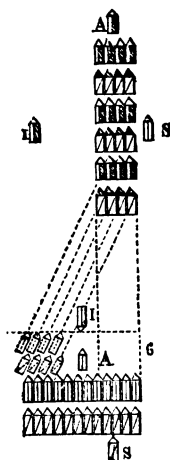

Fig. 40.

Direct March in Column by Twos or by Fours.

The principles of the direct march in column by file, are applicable to the column by twos or by fours.

The trooper on the left of the first rank of twos (or fours) is guide of the column; he keeps his eyes to the front, moves straight forward, and marches so that the troopers of his rank may be at *one* pace from the croup of the sub-instructor's horse. The trooper on the left of each of the other ranks, who is guide of his rank, preserves the head direct, and keeps at the distance of *two* feet from his file-leader, and in the same direction; the other troopers of each rank look occasionally towards the guide, in order to align themselves and regulate upon him their rate of march. They feel lightly the boot towards that side, and yield to all pressure coming from it. When the

march is by fours, they resist all pressure coming from the opposite direction.

When the platoon marches left in front, the guide is to the right, and in other respects the troopers conform to the same principles.

Change of Direction.

The column marching by twos or by fours, right or left in front, the instructor commands:

Head of column to the left (or to the right).

At this command the assistant-instructor commands:

1. *Left*—TURN. 2. FORWARD.

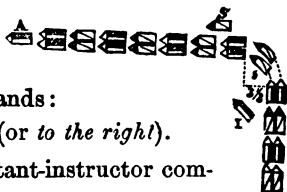

Fig. 41.

Figs. 41 and 42. At the first part of the first command, which is **LEFT**, the left trooper, who is pivot, prepares to turn at the same gait, the trooper of the opposite side to lengthen his.

At the last part of the command, which is **TURN**, the first rank of twos or fours turns to the left. The pivot turns at the



Fig. 42.

same gait, describing an *arc of a circle of five paces*. The trooper on the opposite side turns in lengthening the gait; the other troopers turn the head towards the marching flank, to regulate their rate of march, feeling at the same time lightly the boot on the side of the pivot.

At the command **FORWARD**, the troopers who had increased the gait resume the precise pace at which they were before moving, and the head of the column marches straight forward in the new direction.

Each rank executes the same movement on arriving upon the ground where the first has turned.

The assistant-instructor should give the command *Left* in sufficient time to command **TURN**, when he is at *three*

paces from the point indicated for the change of direction; he executes his movement in lengthening slightly the gait without leaving the centre of the front rank, regulating himself upon the marching flank, so as to give the command FORWARD at the instant the front rank, having executed a quarter of a wheel, is in a direction perpendicular to the former one.

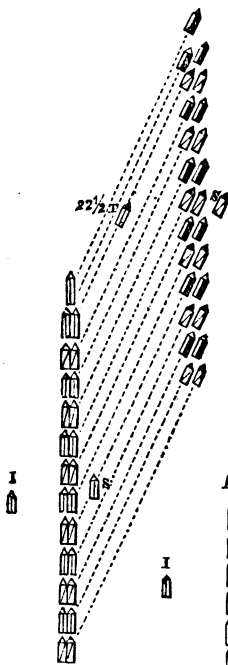

Fig. 43.

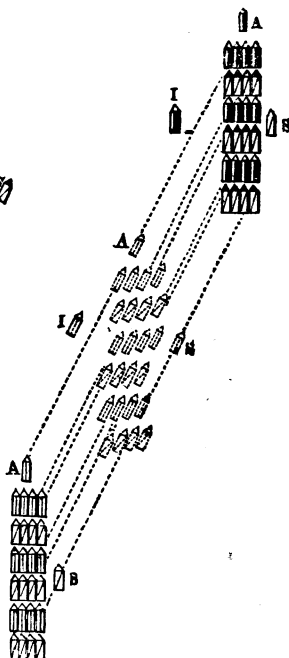

Fig. 44.

Individual Oblique March.

The column marching by twos or by fours, the instructor commands:

1. *Right (or left) oblique.* 2. MARCH.

Figures 43 and 44. At the command MARCH, each trooper executes a *quarter-turn to the right*.

The trooper on the left of the first rank, who is guide of the column, moves straight forward in the new direction, and parallel to the assistant-instructor. The trooper on the left of each of the other ranks, who is guide of his rank, moves forward also in the new direction, observing the guide of the column so as to keep on the same line, and in a parallel direction with him.

The other troopers move forward, looking occasionally to the left so as to align themselves upon their guide. Each one places the right knee behind the left knee of the man on the right, and the head of his horse opposite the lower part of the neck of the horse on his right. The troopers march thus, in each rank, during the oblique march.

To return to the primitive direction the instructor commands—FORWARD, when the troopers make a quarter-turn to the left in advancing, and move forward in direction of their file-leaders.

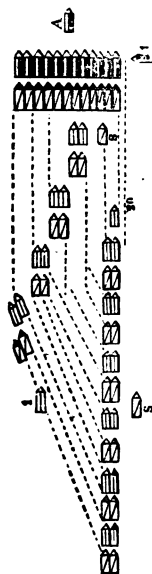

Fig. 45.

The Platoon Marching in Column by Twos or by Fours, to form it to the Front, to the Left, or on Right, into Line.

To form to the front.

The platoon marching in column right in front, to form line to the front, the instructor commands:

1. *Front into line.* 2. MARCH. 3. HALT.
4. *Right—DRESS.* 5. FRONT.

Figures 45 and 46. At the command MARCH, the two (or four) first files continue to march forward; the other ranks of twos (or fours) oblique to the left,

march in this direction, and make a *quarter-turn to the right* on coming opposite the place they are to occupy in the platoon.

When the first files have marched *twenty paces*, the instructor commands **HALT**. At this command, they halt square to the front; the other files come up and form successively on their left, and dress to the right.

At the command **FRONT**, turn the head to the front.

The instructor gives the command *Right-DRESS* immediately after that of **HALT**, and commands **FRONT** when the last rank of twos or fours is aligned.

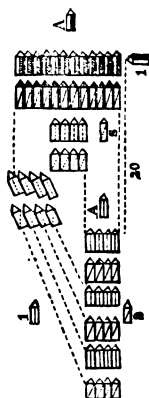

Fig. 46.

To form to the left.

The column marching right in front, to form line upon its left flank, the instructor commands :

1. *Left into line.*
2. **MARCH.**
3. **HALT.**
4. *Right—DRESS.*
5. **FRONT.**

Figures 47 and 48. At the command **MARCH**, the two (or four) first files turn to the left and move straight forward; the other ranks of twos (or fours) continue to march on, and at *three paces* before arriving opposite the place they are to occupy in the platoon, turn successively to the left.

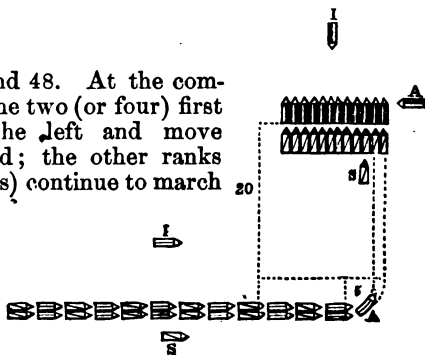

Fig. 47.

When the first files have marched *twenty* paces, the instructor commands: **HALT**. At this command the first files halt square upon the line; the other files come up and form successively on their left, and dress to the right.

At the command **FRONT**, turn the head to the front.

The instructor gives the command *Right*—**DRESS** immediately after that of **HALT**, and commands **FRONT** when the two (or four) last files are aligned.

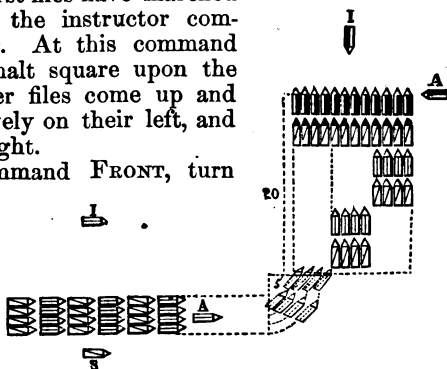
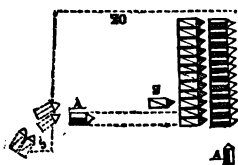

Fig. 48.

To Form on the Right into Line.



The column marching right in front to form line upon the prolongation, and in advance of its right flank, the instructor commands:

1. *On the right into line.*
2. **MARCH.**
3. **HALT.**
4. *Right*—**DRESS.**
5. **FRONT.**

Figures 49 and 50. At the command **MARCH**, the two (or four) first files turn to the right and move straight forward; the other ranks of twos (or fours) continue to march on, and each turns successively to the

Fig. 49.

At the command **HALT**, the trooper on the left halts, and successively the others, on arriving abreast of him.

At the command *Right—DRESS*, all the troopers of the rear rank dress to the right.

At the *sixth* command, which is **FRONT**, turn the head to the front.

The instructor gives the third command, which is **FRONT**, the moment that one-third of the rear rank in column have passed the front rank; he commands *Right—DRESS*, when the trooper on the right of the rear rank has fronted.

To Form the Platoon to the Right in Two Ranks.

The platoon being in one rank, the instructor designates the trooper who is to be on the left of the front rank, also the one to be on the right of the rear rank, and commands:

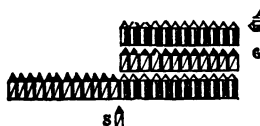

Fig. 52.

1. *Right into two ranks.* 2. **MARCH.** 3. *Right—DRESS.*
4. **FRONT.**

Figure 52. At the command **MARCH**, the front rank moves forward *six* paces, dressing by the right; the trooper on the right of the rear-rank *turns to*

the right as soon as the front rank has passed, and moves forward obliquing to the right; when he is nearly in rear of the trooper on the right of the front rank, he fronts by *turning to the left*. All the other troopers execute successively the same movement, placing themselves exactly behind their file-leaders and at their proper distances.

At the command *Right—DRESS*, all the troopers align themselves to the right.

At the command **FRONT**, turn the head to the front.

The instructor gives the command *Right—DRESS*, when the trooper on the right of the rear rank has turned to the front.

To Form Twos and Fours at the same Gait.

The platoon marching in column by file, right in front, to form twos the instructor commands:

1. *Form twos.*
2. MARCH.

Figure 53. At the command MARCH, the first file continues to march on, and halts when it has marched *ten* paces; the second file obliques to the left, and comes up abreast of the first; on arriving there, it halts and dresses to the right. All the other files continue to march straight forward, Nos. *two* and *four* executing their movement in the same manner, but successively, and when Nos. *one* and *three*, upon which they should form, have nearly arrived at their proper distance, and are about to halt.

The platoon marching in column by twos, right in front, to form fours the instructor commands:

1. *Form fours.*
2. MARCH.

Figure 54. At the command MARCH, the two first files continue to march on, and halt when they have marched *ten* paces; the two following files oblique to the left, and come up abreast of the first two; on arriving there, they halt and dress to the right. All the other files continue to march straight forward, Nos. *three* and *four* executing their movement in the same manner, but successively, and when Nos. *one* and *two*, upon which they should form, have nearly arrived at their proper distance, and are about to halt.

When the column is *at a trot*, the formation of twos and fours at the same gait is executed following the same principles. The first, or first two files, pass *to the walk*, at the

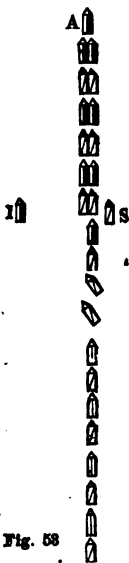

Fig. 53.

when they



Fig. 54.

command **MARCH**; the others continue to march *at the trot*, until they have arrived abreast of those on which they should form; then they pass *to the walk*.

When the column is *at a gallop*, the movement is executed following the same principles. The first, or first two files, pass *to the trot* at the command **MARCH**; the others continue to march *at the gallop*, until they have executed their formation: then they pass *to the trot*.

To Break by Twos and by File at the same Gait.

To Break by Twos.

The platoon marching in column by fours, right in front, to break by twos the instructor commands:

1. *By twos.* 2. **MARCH.** 3. *Guide left.*



Fig. 55.

Figure 55. At the command *By twos*, all the troopers prepare to halt, except Nos. *one* and *two* of the leading files.

At the command **MARCH**, Nos. *one* and *two* of the leading files continue to march at the same gait; all the others halt. Files *three* and *four* of the leading rank oblique to the right the moment they are passed by the croup of the horses of the rear rank of Nos. *one* and *two*, and place themselves in column behind them.

Each rank of fours executes successively the same movement, files *one* and *two* breaking as soon as files *three* and *four* of the rank which precedes them have commenced obliquing in order to enter the column.

Files *one* and *two*, which break to the front, regulate their gait so as to preserve their distances; and files *three* and *four* keep their horses straight so as not to constrain the movements of files *one* and *two*.

To break by file.

The platoon marching in column by twos, right in front, to break by file, the instructor commands:

1. *By file.*
2. MARCH.

Figure 56. At the command *By file*, all the troopers prepare to halt except the right file of the leading rank of twos.

At the command MARCH, the right file of the leading rank of twos continues to march at the same gait; all the others halt. The left file of this same rank obliqués to the right, the moment it is passed by the croup of the rear rank horse of No. one, and places itself in column behind the first file.

Each rank of twos executes successively the same movement, files *one* and *three* breaking as soon as files *two* and *four* who precede them have commenced obliquing in order to enter the column.

Files *one* and *three*, which break to the front, regulate their gait so as to have their distances. Files *two* and *four* keep their horses straight, so as not to constrain the movements of files *one* and *three*.

When the column is *at the trot*, to break by twos or by file is executed on the same principles; the right files of the leading rank continue *at the trot*; all the others take *the walk* at the command MARCH, and resume *the trot*, in order to enter the column; when the column is *at the gallop*, the files which are to break take *the trot* at the command MARCH, and afterwards resume *the gallop* on entering the column.

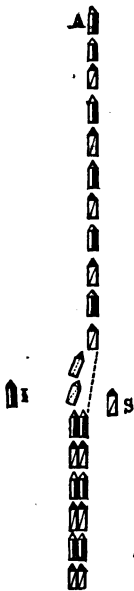

Fig. 56.

To Form Twos and Fours in Doubling the Gait.*To form twos.*

The platoon marching in column by file, right in front, to form twos the instructor commands :

1. *Form twos—trot.* 2. MARCH. 3. *Guide left.*

At the command *Form twos—trot*, all the troopers prepare to take *the trot*, except the leading file.

At the command MARCH, all the troopers take *the trot*, except the leading file; the second file obliquely to the left, and comes up abreast of the first; on arriving there it takes *the walk*; all the other files continue to march forward *at the trot*. Files *four* and *two* execute their movement in the same manner, but successively, when *three* and *one*, upon whom they are to form, have nearly arrived at their distance, and are about to pass to *the walk*.

To form fours.

The platoon marching in column by twos, right in front, to form fours the instructor commands :

1. *Form fours—trot.* 2. MARCH. 3. *Guide left.*

At the command *Form fours—trot*, all the troopers prepare to take the trot, except the two leading files.

At the command MARCH, all the troopers take *the trot*, except the two leading files; the two following files oblique to the left, and come up abreast of the two first; on arriving there they resume *the walk*; all the other files continue to march forward *at the trot*. Files *three* and *four* execute their movement in the same manner, but successively, when files *one* and *two*, upon whom they are to form, have nearly arrived at their distance, and are about to pass to *the walk*.

When the column is *at the trot*, the movement is executed on the same principles. At the command MARCH, all the troopers pass to *the gallop*, except the files at the head of the column, and resume the *trot* when their formation is executed.

To Break by Twos and by File in Doubling the Gait.*To break by twos.*

The platoon marching in column by fours, the instructor commands:

1. *By twos—trot.*
2. **MARCH.**
3. *Guide left.*

At the command *by twos—trot*, files *one* and *two* of the leading rank of fours prepare to *trot*.

At the command **MARCH**, they commence the *trot*; all the other files continue to march *at the walk*; files *three* and *four* take the *trot* successively and oblique to the right, in order to place themselves in column behind files *one* and *two*.

To break by file.

The platoon marching in column by twos, right in front, to break by file, the instructor commands:

1. *By file—trot.*
2. **MARCH.**

At the command *By file—trot*, the right file of the leading rank of twos prepares to *trot*.

At the command **MARCH**, it commences the *trot*; all the other files continue to march *at the walk*; files *two* and *four* assume the *trot* successively and oblique to the right, in order to place themselves behind files *one* and *three* in the column.

When the column is *at the trot*, to break in doubling the gait, the instructor commands: 1. *By twos (or by file)—gallop*; 2. **MARCH**; which is executed on the same principles.

When the column is at the *gallop*, the files which are to break take the *trot* at the command **MARCH**, and afterwards resume the *gallop* on entering the column.

Direct March of the Platoon in Line.

The principles of the direct march give the troopers the means,

1st. Of preserving the alignments in marching without being disunited;

2d. Of not closing too much, and of recovering the required distances when they have closed;

3d. Of not opening, and of closing upon each other again when they have opened;

4th. Of not throwing the guide out of his direction, and of permitting him to return to it if he has been forced out.

The most important point in the *direct march* being to keep the horses straight in the ranks, it is indispensable that the troopers should preserve the head erect.

To keep themselves aligned, the troopers should feel lightly the boot of the men on the side of the guide, and march at an equal gait.

The troopers should yield to all pressure coming from the side of the guide, and resist that coming from the opposite side.

The guide should always march at a free and steady gait, and change it with steadiness in order to avoid irregularity in the ranks.

If the troopers are in front or in rear of the alignment, too near to or too far from the man on the side of the guide, they move from or approach him gradually, and in gaining ground to the front.

When the guide feels himself thrown out of his direction, he extends his arm to the front to indicate that there is too much pressure toward him. Then the troopers carry the hand toward the opposite side, give a glance to the guide, and straighten their horses as soon as the guide is relieved.

When the platoon is halted, the alignment is ordered towards the side of the guide.

To march the platoon forward, the instructor commands:

1. *Platoon forward.* 2. *Guide right (or left).* 3. **MARCH.**

At the command **MARCH**, all the troopers move straight forward, at the same gait with the men on the side of the guide.

To halt the platoon, the instructor commands:

1. *Platoon.* 2. **HALT.** 3. *Right (or left)—DRESS.*
4. **FRONT.**

At the command **HALT**, the troopers stop.

At the command *Right—DRESS*, they align themselves.

At the command **FRONT**, turn the head to the front.

Counter-march.

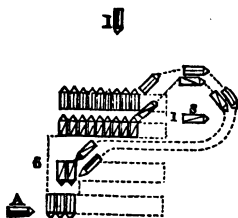

Fig. 57.

The platoon having arrived at the extremity of the ground, in order to change the direction the instructor commands:

1. *Counter-march—by the right-flank.* 2. *By file to the right.*
3. **MARCH.**

Figure 57. At the command *Counter-march—by the right flank*, the assistant instructor places himself facing to the rear at six paces from the rear rank, and in such a position that the trooper who is to be placed on his left may find himself in the direction of the left file of the platoon. The file-closer places himself on the right of the platoon, facing to the right, the croup of his horse one pace from, and on the line of haunches of the horses of the rear rank, in order to mark the wheeling point.

At the command **MARCH**, the trooper on the right of each rank turns to the right, the rear rank man joining

in his movement the front rank man; they then wheel together to the right, the latter lengthening a little his gait; they pass before the file-closer, very near the croup of the horses of the rear rank, and are followed by the other troopers, who execute successively the same movement, taking care to pass over the same ground.

When the first file is within two paces of the assistant-instructor, who indicates the point on which it is to form, the instructor commands:

1. FRONT.
2. HALT.
3. *Right*—DRESS.
4. FRONT.

At the commands FRONT and HALT, the first file turns to the left and halts, the trooper of the rear rank taking care to slacken the pace, and place himself exactly behind his file-leader. All the other files execute successively the same movement.

At the last command, which is FRONT, turn the head to the front.

The instructor gives the command *Right*—DRESS, immediately after that of halt, and commands FRONT when the last file is aligned.

The assistant-instructor and file-closer return to their places.

Wheelings.

There are two kinds of wheels: *the wheel on a fixed pivot*, and *the wheel on a moveable pivot*.

The wheel is always on a *fixed pivot*, except when the command is *right* (or *left*)—TURN.

The troopers should execute this movement without disuniting, and without ceasing to observe the alignment.

In every kind of wheel, the conductor of the marching flank should measure with his eye the arc of the circle he is to pass over, so that it may not be necessary for the files either to open or close. He turns his head occasionally towards the pivot; if he perceives that the troopers are too much crowded, or too open, he increases or dim-

inishes gradually the extent of his circle, in gaining more ground to the front than to the side.

Each trooper in the front rank should describe his circle in the ratio of the distance at which he may be from the pivot. As these different arcs are all passed over in the same time, it is necessary that each trooper should slacken his pace in proportion to the distance from the marching flank.

During the wheel, the troopers should turn the head slightly toward the marching flank, to regulate the rapidity of their march and to keep themselves aligned: they should also feel lightly the boot on the side of the pivot, in order to remain closed to that side. They should, nevertheless, yield to pressure coming from the pivot, and resist that from the opposite direction. The horses are slightly turned toward the pivot, in order to keep them upon the circular line they have to pass over.

In every kind of wheel, the troopers should cease wheeling and retake the direct march at the command FORWARD, at whatever point of the wheel they may be; it is necessary to observe, also, that the flanks which become pivots, or marching flanks, do not slacken or augment the pace before the command of execution.

To Wheel on a Fixed Pivot.

The object of a wheel on a fixed pivot is, when the platoon forms a part of the squadron, to pass from the order of battle to the order of column, and the reverse.

The trooper who forms the pivot of the wheel turns upon his own ground, without advancing or reining back, and without passing to the right or to the left, so that the centre of gravity of his horse remains always on the same point. Thus, in wheeling to the right, the shoulders of the pivot horse describes an arc of circle in passing from left to right, while the haunches describe another in passing from right to left.

The trooper at the pivot should turn his head slightly towards the marching flank, that he may continue aligned on the conductor of that flank.

When the platoon is marching the pivot halts, and the marching flank executes its movement at the same gait as before the wheel.

If the instructor indicates a new gait, in order to wheel, the marching flank wheels at this gait; all the other troopers, who regulate the rapidity of their march in accordance with their distance from the marching flank, take freely the new gait at the command FORWARD.

When the platoon is halted after a wheel on a fixed pivot, the alignment is always ordered toward the side of the marching flank; but as the pivot should never move from its place, the marching flank should come up abreast of it.

When the platoon is marched forward after a wheel on a fixed pivot, the guide is ordered on the side of the marching flank, immediately after the command FORWARD, unless the movement of the platoon in the squadron requires the contrary.

The wheelings are executed at first in single rank: for this purpose the front rank is marched forward, and halted when arrived at a distance from the rear rank equal to double its front; the file-closer remains at his place; the assistant-instructor places himself behind the front rank; each of them observes the rank behind which he is placed.

The ranks being aligned, the instructor commands:

1. *Platoon in circle right (or left) wheel.*
2. MARCH.

Figure 58. At the command MARCH, the troopers put themselves in motion, turning the head toward the marching flank. The non-commissioned officer who conducts this flank marches *ata walk*, measuring with the eye the extent of the circle he is to pass over, that neither opening nor closing may be caused in the rank, and that the troopers may keep aligned. The pivot

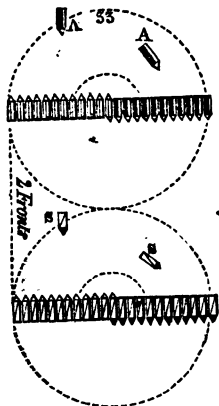

Fig. 58.

The two ranks are then marched forward, preserving between them the same distance, and made to recommence the wheel. When the instructor wishes the platoon to take the direct march, he commands :

1. FORWARD. 2. *Guide left (or right).*

At the first command, which is FORWARD, the pivot resumes the gait at which it was previously marching.

All the other troopers straighten their horses, and the two flanks move forward at the same gait, conforming to the principles of the direct march.

At the command *guide left (or right)*, the troopers regulate their movement toward the side indicated.

When the troopers have executed several wheels to the right and to the left, interrupted occasionally by direct marches, and when the horses become calm, the instructor causes them to pass to the trot; after several wheels at the trot, they resume the walk.

If the platoon is wheeling to the right, and the instructor wishes it to change the wheel to the left without halting, he commands :

man turns upon his own ground, regulating himself upon the marching flank.

When the platoon has made several wheels, to halt it the instructor commands :

1. *Platoon.* 2. HALT. 3. *Left (or right)*—DRESS. 4. FRONT.

At the command HALT, the troopers straighten their horses and halt with steadiness.

At the command *Left (or right)*—DRESS, they align themselves toward the side indicated.

At the command FRONT, turn the head to the front.

1. *Platoon in circle left wheel.* 2. MARCH.

At the command MARCH, the left flank halts, and becomes the pivot. The right flank assuming the gait at which the left flank was marching, moves forward and describes a circle proportionate to the extent of the front. All the other troopers straighten their horses, and guide them so as to pass over new circles in an inverse sense.

The troopers being sufficiently exercised at the wheels, in single rank *at the walk and the trot*, the ranks are closed and the wheels executed by platoon, in following the same gradation.

The instructor commands :

1. *Platoon in circle right (or left) wheel.* 2. MARCH.

Fig. 59. At the command MARCH, the troopers of the front rank execute this movement, as prescribed. The troopers of the rear rank turn the head and carry the hand towards the marching flank, so that each one may be out of the direction of his file-leader by two troopers. For this purpose, the moment the wheel commences, each rear rank man executes a *quarter-turn to the left*, sustaining the haunches of the horse with the right leg,

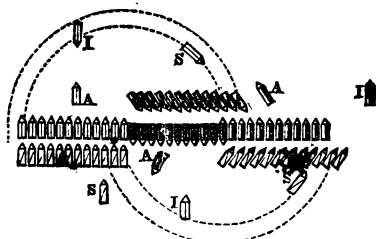

Fig. 59.

when the wheel is to the right, (or a *quarter-turn to the right*, in sustaining the haunches of his horse with the

left leg when the wheel is to the left,) keeping during the wheel in the direction of his new file-leader, and remaining at the distance of *two* feet from the front rank. The two rear rank men on the marching flank, who are without file-leaders, should describe their circle without being farther outside of the front rank than is necessary, and be able to resume their places behind their file-leaders easily. During the wheel, they should regulate their gait, so that the rear rank, which aligns itself upon them, may be at its proper distance.

To stop the wheel, the instructor commands :

1. *Platoon.* 2. **HALT.** 3. *Left (or right)—DRESS.*
4. **FRONT.**

At the command *Platoon*, the rear rank men straighten their horses and return to the direction of their file-leaders.

At the command **HALT**, all the troopers stop.

At the command *Left (or right)—DRESS*, they align themselves towards the side indicated.

At the command **FRONT**, turn the head to the front.

When the instructor wishes the platoon to resume the direct march, he commands :

1. **FORWARD.** 2. *Guide left (or right).*

At the first command, which is **FORWARD**, the rear rank men replace themselves behind their file-leaders, and march straight forward.

To give the troopers the habit of correcting faults, the pivot man is directed to bear against the rank, so that the other troopers, feeling the pressure from that direction, may learn to gain ground towards the marching flank. The pivot is then directed to gain ground in the opposite direction, which would require the other troopers to approach him gradually.

When the troopers have acquired in the execution of these movements, *at the walk*, the intelligence and skill necessary to avoid confusion, they are repeated *at the trot*.

The platoon being halted, to place it in a direction

perpendicular to the original front, the instructor commands :

1. *Platoon right (or left) wheel.* 2. MARCH. 3. HALT.
4. *Left (or right)—DRESS.* 5. FRONT.

Which is executed on the same principles of the wheel on a fixed pivot.

The instructor gives the command HALT, when the marching flank has nearly terminated its wheel.

The platoon being halted, to face it to the rear, the instructor commands :

1. *Platoon right-about (or left-about) wheel.* 2. MARCH.
3. HALT. 4. *Left (or right)—DRESS.* 5. FRONT.

Which is executed following the principles prescribed for a wheel on a fixed pivot, the platoon passing over a half circle.

The instructor gives the command HALT, when the marching flank has nearly completed the half circle, and the platoon is on a line parallel to the original front.

The platoon being halted, to place it towards its right in a direction oblique to the original front, the instructor commands :

1. *Platoon right half (or left half) wheel.* 2. MARCH.
3. HALT. 4. *Left (or right)—DRESS.* 5. FRONT.

Which is executed on the principles of the wheel on a fixed pivot.

The instructor gives the command HALT, when the marching flank has nearly completed its half-wheel to the right or to the left.

Before dressing the platoon, the trooper on the marching flank is made to come up abreast of the pivot man, so that the other troopers will not have to rein-back in order to align themselves.

The platoon being on the march, the same movements are executed at the commands: 1. *Platoon right (or left) wheel, right-about (or left-about) wheel, right-half (or*

left-half) wheel: 2. MARCH; 3. FORWARD; 4. *Guides right* (or *left*).

At the command MARCH, the wheeling flank wheels at the gait at which the platoon was marching; the pivot flank halts.

At the third command, which is FORWARD, the pivot resumes its original pace, and the two flanks move forward at the same gait.

These movements being properly executed from a halt and *at the walk*, are repeated *at the trot*.

To Wheel on a Moveable Pivot.

The wheel on a moveable pivot is employed in the successive changes of direction in column.

In this wheel, the object of the moveable pivot is to leave by degrees the ground on which the movement commences, by advancing in the new direction.

The conductor of the marching flank should increase his gait and describe his arc of circle so as to cause the files neither to open nor close. The pivot describes *an arc of five paces* in slackening the gait. In each rank, the troopers from the centre to the marching flank increase the gait progressively, so that the centre man preserves the gait at which the platoon was marching. The troopers from the centre to the pivot slacken the gait progressively. At the end of the wheel on a moveable pivot, the portion of the rank which had augmented its gait should slacken it, and that which had slackened its gait should augment it. All the troopers straighten their horses; the marching flank and the pivot resume the gait at which they originally marched.

The platoon being on the march, and supposed to be the head of the column, to cause it to change direction, the instructor commands:

Head of column to the right (or *to the left*).

At this command, the assistant-instructor commands:

1. *Right* (or *left*)—TURN. 2. FORWARD.

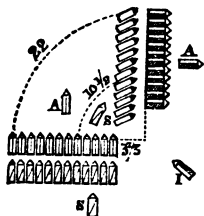

Fig. 60.

Fig. 60. At the first part of the first command, which is *right* (or *left*), the pivot prepares to slacken, and the marching flank to augment the gait.

At the second part of the same command, which is **TURN**, the platoon turns to the left or to the right, the pivot slackening its gait, in describing *an arc of five paces*; the marching flank augments its gait, and regulates itself by the pivot during the whole of the wheel.

At the last command, which is **FORWARD**, all the troopers straighten their horses, the pivot and marching flank moving forward in the gait at which the platoon was originally marching.

Individual Oblique March.

The platoon marching in line, to cause it to gain ground towards one of its flanks, without changing the front the instructor commands;

1. *Right* (or *left*) *oblique*. 2. **MARCH**.

Fig. 61. At the command **MARCH**, the troopers execute, all at the same time, a *quarter-turn to the right*, so that the head of each horse may be opposite the extremity of the neck of the horse on his right, and that the right knee of each trooper may be in rear of the left knee of the trooper on his right. The first movement being executed, the troopers move forward in the new direction, regulating themselves upon the guide.

When the platoon has obliques sufficiently, the instructor commands: **FORWARD**.

At this command, the troopers straighten their horses, and move forward, regulating themselves upon the guide.

In the oblique march, the guide is always on the ob-

liquing side, without being indicated; and after the command FORWARD, the guide returns, without indication, to the side on which it was originally.

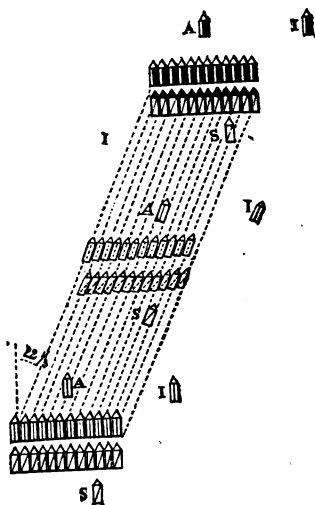

Fig. 61.

The Platoon Marching in Line, to Break it by Fours or by Twos at the same gait.

The instructor commands:

1. *By fours (or by twos).* 2. MARCH. 3. *Guide left.*

At the command MARCH, the four (or two) first files of the right continue to march forward at the same gait; the other files halt and break successively by fours (or

by twos), according to the principles prescribed for breaking from a halt.

The platoon marching in line, to break it by file, the movement is executed on the same principles, the first file only continuing to march forward.

The platoon marching *at the trot*, it is broken on the same principles, the first files continuing to march at the same gait, all the other files assume *the walk* at the command MARCH, and resume *the trot* as they break from the platoon.

The Platoon Marching in Column by Twos or by Fours, to Form it at the same Gait.

The platoon marching in column, right in front, the instructor commands :

1. *Form Platoon.* 2. MARCH. 3. *Guide right.*

The movement is executed as prescribed for *front into line* from a halt.

The platoon marching in column *at the trot*, right in front, the instructor commands :

1. *Form platoon.* 2. MARCH. 3. *Guide right.*

At the command MARCH, the two (or four) first files pass *to the walk*; the other files continue to march at the same gait, oblique immediately to the left, march straight forward in this direction, make a *quarter turn to the right* on coming opposite the place they are to occupy in the platoon, and pass *to the walk* on arriving upon the alignment of the first.

At the command *Guide right*, they dress towards the right.

When the command is *at the gallop*, the platoon is formed on the same principles. The two (or four) first files take *the trot*, at the command MARCH; the other files continue to march *at the gallop*, and take *the trot* on arriving upon the alignment of the first.

The Platoon Marching in Line, to Break it by Fours or by Twos, in Doubling the Gait.

The instructor commands :

1. *By fours (or by twos)—trot.* 2. MARCH. 3. *Guide left.*

At the command MARCH, the four (or two) first files of the right take *the trot*; the others continue to march *at the walk*, and take successively *the trot* when they oblique to the right, in order to enter the column.

The platoon marching *at the trot*, the instructor commands :

1. *By fours (or by twos)—gallop.* 2. MARCH. 3. *Guide left.*

Which is executed according to the principles prescribed for marching at a walk.

The Platoon Marching in Column, by Twos or by Fours, to Form it in Doubling the Gait.

The platoon marching in column, right in front, the instructor commands :

1. *Form platoon—trot.* 2. MARCH. 3. *Guide right.*

At the command MARCH, the two (or four) first files continue to march forward at the same gait; the other files take *the trot*, oblique immediately to the left, march in this direction, make a *quarter-turn to the right* on coming opposite the place they are to occupy in the platoon, and pass *to the walk* on arriving upon the alignment of the first.

At the command *Guide right*, they dress towards the right.

The platoon marching in column *at the trot*, the right in front, the instructor commands :

1. *Form platoon—gallop.* 2. MARCH. 3. *Guide right.*

When the column is *at the gallop*, the platoon is always formed at the same gait.

When the column is marching by file, the platoon is formed on the same principles.

Movements by Fours, the Platoon being in Column or in Line.

The platoon being in column, right in front, the instructor commands :

1. *By fours—left (or right) wheel.*
2. MARCH.

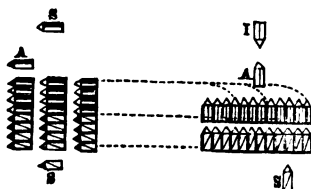

Fig. 62.

Figure 62. At the command MARCH, each rank of fours executes its wheel to the left, according to the principles of the wheel on a fixed pivot; Nos. four turn upon themselves, sustaining with the left leg the haunches of their horses,

in order not to constrain the movement of the rank immediately behind them; all the troopers regulate themselves towards the marching flanks.

The movement being nearly completed, the instructor commands :

1. HALT.
2. *Right (or left) —DRESS.*
3. FRONT.

At the command HALT, the troopers straighten their horses and halt with steadiness.

In this movement the front and rear rank execute separately a wheel on a fixed pivot. Each rank of fours belonging to the rear rank is placed at the side of the rank of fours, composed of its file-leaders. When the movement is terminated, the platoon is in one rank.

The platoon being in one rank, it is put again in column by the command :

1. *By fours left (or right) wheel.*
2. MARCH.

Then the troopers of the rear rank are placed in front of their file-leaders. In executing again two *wheels to the left by fours*, the platoon is put in its natural order.

In the first *wheel to the left by fours*, the leading rank of fours should execute its movements slowly, in order to give the others time to execute theirs; but in the second *wheel to the left by fours*, the last rank of fours, which becomes head of the column, should execute its movement in lengthening a little the gait, so as not to retard the rear of the column.

The platoon being in column, and having executed a wheel by fours as above described, to face it in the opposite direction, the instructor commands:

1. *By fours left-about (or right-about) wheel.* 2. MARCH.

At the command MARCH, each rank of fours *wheels to the left-about* on the principles prescribed for the *wheel to the left by fours*.

To halt, after having wheeled about, the instructor commands:

1. HALT. 2. *Right (or left)—DRESS.* 3. FRONT.

To put the platoon again in column in the natural order, the instructor causes to be executed a *wheel to the left by fours*.

When the column is marching, the movement is executed as prescribed, observing that, at the command MARCH, the pivots halt immediately and turn upon themselves, supporting with the left leg the haunches of their horses.

The movement being nearly terminated, the instructor commands:

1. FORWARD. 2. *Guide right (or left).*

At the first command, which is FORWARD, the pivots and all the other troopers, conforming to the principles of the direct march, regulate themselves towards the guide.

The platoon marching in column, and having made

one *wheel to the left by fours*, which puts it in single rank, the instructor causes to be executed a *wheel to the left-about* (or *to the right-about*) *by fours*; the movement being nearly terminated, he commands :

1. FORWARD. 2. *Guide right* (or *left*).

To put the platoon again in column in the natural order, the instructor causes to be executed a *wheel to the left* (or *to the right*) *by fours*, and indicates the guide to the left.

The platoon marching in column by fours, right in front, to cause it to march to the rear, the instructor commands :

1. *By fours left-about* (or *right about*) *wheel*. 2. MARCH.
3. FORWARD. 4. *Guide right* (or *left*).

Which is executed on the principles prescribed for the same movement from a halt, observing that the ranks of fours should finish the movement at the same time; that they should commence the last half of the wheel gently, regulating themselves upon the last rank of fours, which, becoming the head of the column, lengthens the gait so as not to retard the others. After this movement, the troopers of the rear rank are placed in front of their file-leaders.

To put the column again in the natural order, the instructor causes to be executed a *wheel to the right-about* (or *to the left-about*) *by fours*.

The platoon being in line, to cause it to gain ground towards its right or towards its left, the instructor commands :

1. *By fours right* (or *left*) *wheel*. 2. MARCH. 3. FORWARD.
4. *Guide left* (or *right*).

The platoon having *wheeled to the right by fours*, the troopers are formed upon a front of eight. Each rank of fours having executed the movement separately, the four troopers of the rear rank find themselves on the right of the four troopers of the front rank.

The platoon having *wheeled to the right* (or to the left) *by fours*, and being upon a front of eight, to change the direction, the instructor commands :

Head of column to the left (or to the right).

At this command the assistant-instructor commands :

1. *Left* (or *right*)—TURN. 2. FORWARD.

This is executed as prescribed, each rank of eight wheeling upon the same ground with the first as they reach it.

To put the platoon again in line, the instructor commands :

1. *By fours left* (or *right*) *wheel*. 2. MARCH. 3. HALT.
4. *Right* (or *left*)—DRESS. 5. FRONT.

The platoon having *wheeled to the right* (or to the left) *by fours*, and being formed upon a front of eight, to march to the rear in this order, the instructor causes to be executed a *wheel to the right* or *left about*.

The platoon being in line, to cause it to march to the rear, the instructor commands :

1. *By fours left-about* (or *right-about*) *wheel*. 2. MARCH. 3. FORWARD. 4. *Guide right* (or *left*).

Figure 63. After this movement, the rear rank is before the front rank, and the ranks of fours are inverted throughout the platoon.

In the march to the rear, the platoon conforms to the principles of the direct march. The instructor requires the same precision as when they march in the natural order.

The platoon is faced to the front by the same movement.

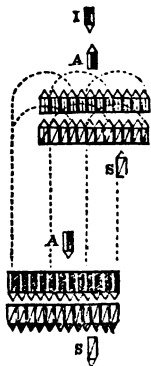

Fig. 63.

To Charge by Platoon.

The charge will be practised by file, by twos, fours, and sections, before the charge by platoon.

Two troopers being stationed at two hundred paces from the line to mark the new line.

To commence the move, the assistant-instructor commands:

1. *Platoon forward.* 2. *Guide right (or left).* 3. MARCH.

When the platoon has marched *twenty* paces, the assistant-instructor commands:

1. *Trot.* 2. MARCH.

At *sixty* paces farther, he commands:

1. *Gallop.* 2. MARCH.

At *eighty* paces farther, he commands:

CHARGE.

At this command, the troopers of both ranks take the position of *Raise—SABRE*. They give hand and lengthen the gallop, without losing control of their horses or disuniting.

When the platoon arrives at *twenty* paces from the troopers who trace the new line, the assistant-instructor commands:

1. *Attention.* 2. *Platoon.* 3. HALT. 4. *Right (or left)—DRESS.* 5. FRONT.

At the command *Attention*, the troopers carry the sabre to the shoulder.

At the command *Platoon*, they take *the trot*.

At the command HALT, they stop.

At the command *Right—DRESS*, they align themselves to the right.

At the command FRONT, turn the head to the front.

PART FIFTH.

SCHOOL OF THE SQUADRON.

ARTICLE FIRST.

The object of the *school of the squadron* is to instruct the platoons to execute together what they have been taught separately, and to prepare the squadron to perform what it will be required to do when a part of the regiment.

To make the formations in line better understood, they are executed at first from a halt. In this case each platoon performs its movements separately and successively, at the command of its chief, on receiving notice from the captain commanding.

Each movement, after having been correctly executed by the right, is repeated by the left.

When the squadron has acquired calmness and confidence, and one article is well understood, this article is repeated with sabres drawn, and alternately at all the gaits, except the *wheels to the right, to the left, to the right-about, and to the left about by fours, the counter-march, the wheels on a moveable pivot by squadron; the individual oblique marches when marching by squadron*, which are executed only at the *walk* and at the *trot*.

The second captain is charged with the alignment of the rear-rank and the rank of file-closers; he resumes his place in line at the command **FRONT**.

The captain commanding moves wherever his presence

is most required; the troopers are required to observe absolute silence, and all rectifications are done by signs, or in a low voice.

The squadron being formed in two ranks opened, the non-commissioned officers and troopers at the head of their horses, the chiefs of platoon mounted, at *ten* paces from, and facing the centre of their platoons, the captain commanding commands:

1. *Attention.* 2. *Right*—DRESS. 3. FRONT.

He then commands:

In each platoon—and in each rank—COUNT (by) FOURS.

At this command, the troopers count off in the four platoons at once, commencing on the right of each rank.

The captain commanding then gives the command to mount.

At the command *Form*—RANKS, the chiefs of platoons move forward, face to the front by *turning to the right-about*, and place themselves before the centre of their platoons, the croup of their horses *one* pace from the head of the horses of the front rank. The file-closers follow the rear rank.

Successive Alignment of Platoons in the Squadron.

The squadron being in line, the captain commanding places the two non-commissioned officers, principal guides of the right and left, upon a line parallel to the front of the squadron, at *thirty* paces from the particular guides, and facing each other as if they were placed on intermediate points.

On receiving notice from the captain-commanding, the chief of the first platoon commands: 1. *Platoon forward*: 2. *Guide right*: 3. MARCH.

At the command MARCH, the platoon moves forward; at one pace from the point which marks the new alignment, the chief of the platoon commands: 1. HALT. 2 *Right*—DRESS.

At the command **HALT**, the chief of the platoon and the particular guide of the right, continue to march on and establish themselves immediately, the latter bringing the head of his horse against the boot of the principal guide of the right.

The first platoon being correctly aligned, the first captain commands:

1. *By platoon—Right—DRESS.*
2. **FRONT.**

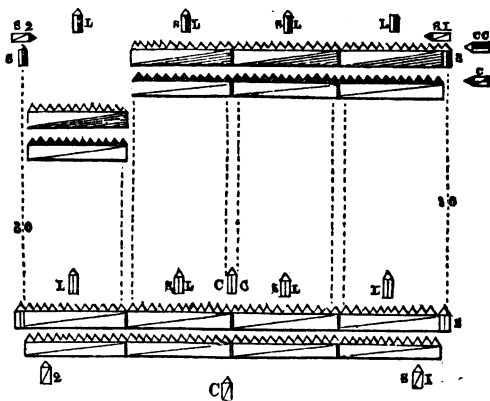

Fig. 64.

Figure 64. At the first command, the chief of the second platoon commands: 1. *Platoon forward*: 2. *Guide right*: 3. **MARCH**. Having arrived abreast of the file-closers of the platoon which forms the base of the alignment, he commands: 1. **HALT**: 2. *Right—DRESS*, and at the same time moves forward on the line of the chief of that platoon.

At the command **HALT**, the platoon stops. At the command *Right—DRESS*, all the troopers move forward together upon the alignment.

Each chief of platoon executes successively the same

movement, commanding MARCH when the one who precedes him has commanded HALT.

The particular guide of the left, at the command HALT from the chief of the fourth platoon, brings up the head

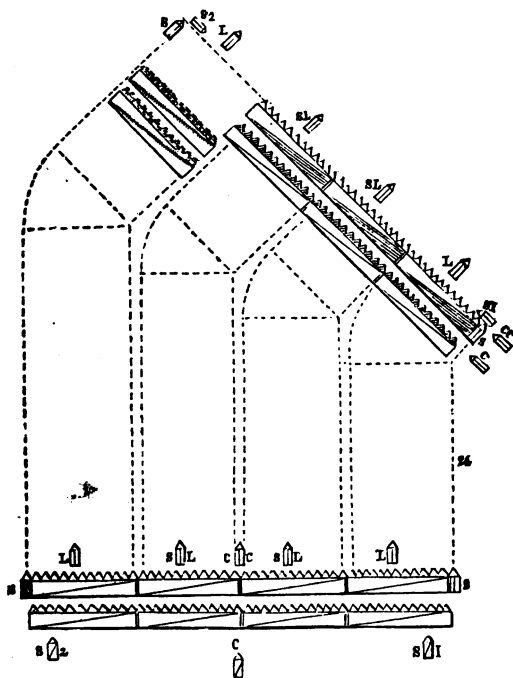

Fig. 65.

of his horse against the boot of the principal guide of the left.

The squadron being aligned, the captain commanding commands: FRONT.

This alignment being correctly executed, it is repeated giving the new base of alignment a direction oblique to the front of the squadron. For this purpose, the chief of the first platoon, on receiving notice from the captain-commanding, moves his platoon *twenty-four* paces forward, causes it to execute a half-wheel to the right at the commands: 1. *Right half*—WHEEL; FORWARD; and after marching it six paces in the new direction, he halts, and aligns it.

The first platoon being correctly aligned, the first captain commands:

1. *By platoon—Right*—DRESS. 2. FRONT.

Figure 65. At the first command, the movement is executed successively; each chief of platoon moves straight forward, and commands: 1. *Right half*—WHEEL; 2. FORWARD, so that his platoon may execute its wheel on a fixed pivot at the moment the right arrives opposite the left of the platoon which precedes it.

The squadron being aligned, the first captain commands: FRONT.

Alignment of the Squadron.

The captain commanding, after having placed the right particular guide, so that no trooper will be compelled to rein back, commands:

1. *Right*—DRESS. 2. FRONT.

At the command *Right*—DRESS, all the troopers align themselves steadily but promptly to the right.

The squadron being aligned, the first captain commands: FRONT.

To Open and Close the Ranks.

To open the ranks, the first captain commands:

1. *Rear rank open order*. 2. MARCH. 3. *Right*—DRESS.
4. FRONT.

This is executed as described in the School of the

Platoon. The troopers of the rear rank rein-back *six* paces; and the chiefs of platoon, at the command MARCH, move forward *six* paces, and face the centre of their platoons by *turning to the left-about*.

To close the ranks, the first captain commands :

1. *Rear rank close order.* 2. MARCH. 3. *Right—DRESS.*
4. FRONT.

This is executed as prescribed in the School of the Platoon. The chiefs of platoon move forward at the command MARCH, face to the front by a *turn to the right-about*, and place themselves opposite the centre of their platoons.

To Break the Squadron by Fours.

The squadron being in line, the first captain commands :

1. *By fours.* 2. MARCH. 3. *Guide left.*

At the first command, the chief of the first platoon places himself in front of the four files of the right, the right particular guide places himself on his right.

At the command MARCH, the first four files march straight forward, and are followed by all the other files who break successively.

The chiefs of the other platoons break with the first four files of their platoons, keeping abreast of them and at *one* pace from the flank of the column on the side of the guide, each rank of fours preserving between them the distance of *two* feet.

On arriving upon the drill ground the first captain commands :

1. *Column.* 2. HALT.

Direct March in Column by Fours.

When the column is halted, the captain commanding assures himself that the officers, the file closers, and the particular guides, are placed as prescribed ; then he commands :

1. *Column forward.* 2. MARCH. 3. *Guide left.*

The column having marched by fours, a quarter of an hour at least, the first captain commands :

1. *Trot.* 2. MARCH.

At the command MARCH, the troops take *the trot*, always taking care not to fret their horses, and to calm them should they become restive.

When the column has marched about *one thousand paces at the trot*, the first captain commands :

1. *Walk.* 2. MARCH.

Change of Direction.

The column marching in column by fours, right in front, to change the direction, the first captain commands :

Head of column to the left (or to the right).

This is executed as prescribed in the School of the Platoon, the chief of the first platoon conforming to what is indicated for the assistant-instructor.

Individual Oblique March.

The squadron marching in column by fours, right in front, to cause it to execute the individual oblique march, the first captain commands :

1. *Left (or right) oblique.* 2. MARCH.

Which is executed as prescribed in the School of the Platoon.

The Squadron Marching in Column by Fours, to Form it to the Front, to the Left, or on Right into Line.

To form Front into Line.

The squadron marching in columns by fours, right in front, the first captain commands :

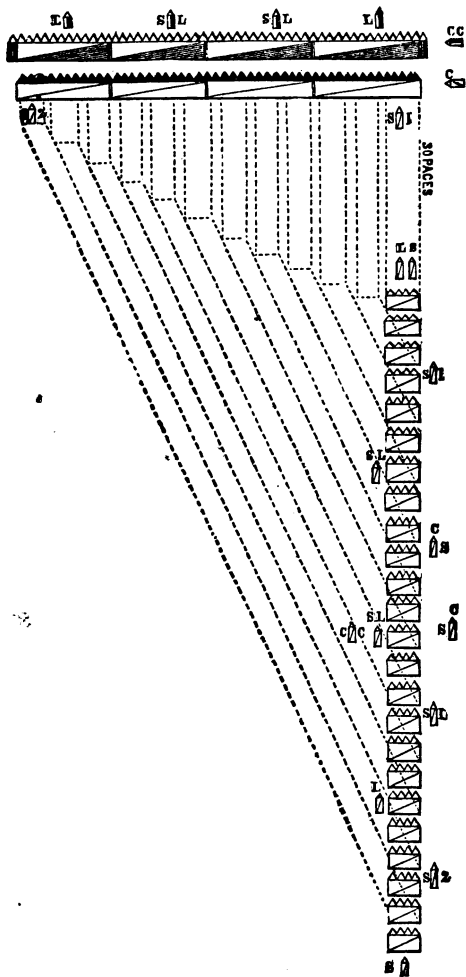

Fig. 61.

560849

1. *Front into Line.*
2. MARCH.
3. *Right—DRESS.*
4. FRONT.

Figure 66. At the command MARCH, the four first files continue to march straight forward; when they have marched *thirty* paces, the chief of the first platoon commands: HALT.

At this command, the first four files halt square to the front, the particular guide of the right returns to the right of the squadron. All the other files come up successively, and without the commands of the chiefs of platoon, form to the left, and upon the alignment of the first.

The first captain, who moves to the right flank after the command MARCH, commands the alignment when the chief of the first platoon commands: HALT.

The second captain moves also to the right flank, after the command MARCH, in order to rectify the alignment of the rear rank and of the file-closers.

As soon as the chiefs of platoon arrive upon the line, they place themselves at the centre of their platoons and align themselves.

The particular guide of the left returns to the left of the squadron, when the last four files arrive upon the line.

The first captain commands FRONT when the last four files are aligned.

To Form to the Left into Line.

The column marching right in front, to form it in line on its left flank, the first captain commands:

1. *Left into Line.*
2. MARCH.
3. *Right—DRESS.*
4. FRONT.

At the command MARCH, the four leading files turn to the left and march straight forward; when they have marched *thirty* paces, the chief of the first platoon commands: HALT.

At this command, the four leading files halt, and the

particular guide places himself on the right of the squadron. All the other files come up successively, and without the command of the chiefs of platoon, form to the left and on the alignment of the first, observing to keep in the same direction, before turning to the left, so as not to approach the new line until the proper time.

The first and second captains, the chiefs of platoons, and the particular guide of the left, conform exactly to what is prescribed for the *front into line*.

To Form on the Right into Line.

The column marching right in front, to form line upon the prolongation, and in advance of its right flank, the first captain commands :

1. *On right into line.*
2. MARCH.
3. *Right—DRESS.*
4. FRONT.

At the command MARCH, the four leading files turn to the right, and march straight forward ; when they have marched *thirty* paces, the chief of the first platoon commands : HALT.

At this command, the four leading files halt, and the right particular guide takes his place on the right of the squadron. All the other files continue to march forward, and come up successively without the commands of the chiefs of platoon, forming to the left and upon the alignment of the first, observing to keep themselves square in the same direction before turning to the right, so as not to approach the new line before the proper time.

The first and second captains, the chiefs of platoon, and the left particular guide, conform exactly to what is prescribed for the *front into line*.

ARTICLE SECOND.

The Squadron being in Line, to Form it in Column with Distance.

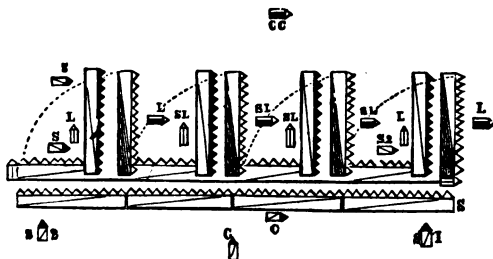

Fig. 67.

The first captain commands :

1. *Platoons right-wheel.* 2. **MARCH.** 3. **HALT.**

Figure 67. At the first command, the left file of each platoon prepares to step off promptly, and the pivot to turn upon its own ground.

At the command **MARCH**, each platoon executes its wheel to the right, following the principles of the wheel on a fixed pivot, the marching flanks taking care to step off and wheel together.

At the command **HALT**, the marching flanks and all the troopers halt at the same instant, those of the rear rank resuming their places behind their file-leaders.

The first captain commands **HALT**, when the platoons have nearly completed the wheels.

To March in Column with Distance.

The squadron being in open column, right in front, the first captain commands :

1. *Column forward.* 2. **MARCH.** 3. *Guide left.*

At the command **MARCH**, all the platoons put themselves in motion at the same time.

Before the column commences the march, the first captain gives the guide of the first platoon a point of direction; this non-commissioned officer selects intermediate points, so as to be sure of marching straight. The fixed object given to the guide of the first platoon, is also pointed out to the guide of the second.

Changes of Direction by successive Wheels.

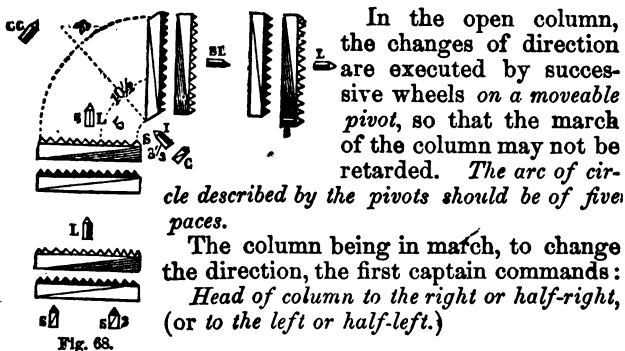

Figure 68. At this command, the chief of the first platoon commands: 1. *Right* — **TURN**. 2. **FORWARD**; which is executed on the principles of the wheel upon a moveable pivot.

Each chief of platoon gives the same commands successively, so that his platoon may turn upon the same ground.

In this change of direction while marching, the principal guide of the right, at the command *head of column to the right*, moves rapidly to the side of the pivot, and places himself so that the head of his horse will mark the centre point of the arc described by the pivot.

All the platoons commence their wheel at *two and a half*

paces before arriving abreast of the head of the horse of the principal guide of the right, so as to prevent the column from being thrown out. This non-commissioned officer resumes his place when the last platoon has completed its wheel.

Immediately after having changed the direction of the column, the first captain gives a new point of direction to the guide of the first platoon.

Individual Oblique March.

The squadron marching in column, with distance, right in front, to cause it to gain ground towards one of its flanks, without changing the front of the column, the first captain commands :

1. *Right* (or *left*) *oblique*. 2.
- MARCH.

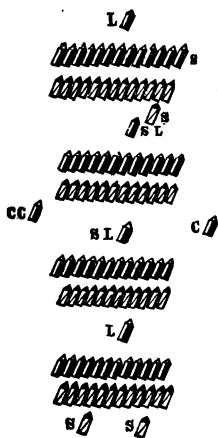

Fig. 69.

Figure 69. Which is executed at the same time, in each platoon, as prescribed in the School of the Platoon.

The guides of the last three platoons pay attention to march on the same line, to preserve their distances, and to keep in a direction exactly parallel to that of the guide of the first platoon.

To resume the primitive direction, the first captain commands :

FORWARD.

Which is executed at the same time, in each platoon, as prescribed in the School of the Platoon.

When the oblique march is executed towards the side opposite to the guide, the file-closers preserve their places notwithstanding the change of guide.

Change of Gait, being in Column with Distance.

The column is made to pass from the *walk* to the *trot*, and from the *trot* to the *walk*, and when the platoons execute these changes of gait with uniformity and steadiness; the column is made to commence the march at a *trot*; and to halt while marching at the *trot*.

To Break by Fours, by Twos, and by File; to form Twos, Fours, and Platoons at the same Gait.

The squadron marching in column with distance, right in front, to break by fours at the same gait, the first captain commands:

1. *By fours.* 2. MARCH. 3. *Guide left.*

At the first command, repeated by the chief of the first platoon, this officer places himself in front of the first four files, and the particular guide of the right places himself on his right.

At the command MARCH, repeated by the chief of the first platoon, this platoon breaks by fours, as prescribed in the School of the Platoon, and the chiefs of the last three platoons command HALT.

The chief of the second platoon, and successively those of the third and fourth command *by fours*, in sufficient time to command MARCH, the moment the last four files of the preceding platoon commence their oblique movement in order to enter the column.

The squadron marching in column by fours, right in front, to break by twos, at the same gait, the first captain commands:

1. *By twos.* 2. MARCH. 3. *Guide left.*

The chiefs of platoon conform to what is prescribed in order to break by fours, and give the commands: HALT, and then 1. *By twos*: 2. MARCH, so as to cause no confusion in the column.

The squadron marching in column by twos, right in front, to break by file at the same gait, the first captain commands :

1. *By file.* 2. MARCH.

Which is executed as prescribed in the School of the Platoon, the particular guide of the right placing himself behind the chief of the first platoon.

The squadron marching in column with distance, at the *trot*, right in front, to break by fours, at the same gait, the first captain commands :

1. *By fours.* 2. MARCH. 3. *Guide left.*

At the first command, repeated by the chief of the first platoon, this officer, and the particular guide of the right, place themselves as prescribed in the School of the Platoon, and the chiefs of the last three platoons command : *Walk.*

At the command MARCH, repeated by all the chiefs of platoon, the first platoon breaks by fours, and the last three platoons take the *walk.*

The chief of the second platoon, and successively those of the third and fourth, command *By fours—trot*, in sufficient time to command MARCH, when the last four files of the preceding platoon commence their oblique movement in order to enter the column.

The same principles are applicable to breaking by twos and by file.

When the column is at the *gallop*, these movements are executed on the principles just prescribed, the whole column except the first four files passing to the *trot* and resuming successively the *gallop*, as the files break in order to enter the column.

The squadron marching in column by file, right in front, to form twos at the same gait, the first captain commands :

1. *Form twos.* 2. MARCH.

At the command *Form twos* and MARCH, successively repeated by the chief of the first platoon, this platoon executes its movement ; the particular guide of the right

moves to the right of the chief of the first platoon, who commands HALT, after having marched *ten* paces.

The three other platoons continue to march by file, and execute successively their formation at the commands of their chiefs, who do not command MARCH until the first files of their platoons arrive at their proper distance.

The squadron marching in column by twos, right in front, to form fours, at the same gait, the first captain commands :

1. *Form fours.*
2. MARCH.

Which is executed as prescribed to form twos.

The squadron marching in column by fours, right in front, to form platoon at the same gait, the first captain commands :

1. *Form platoons.*
2. MARCH.

At the first command, the chief of the first platoon commands : *Form platoon.*

At the command MARCH, repeated by the chief of the first platoon, the particular guide of the right places himself on the right of this platoon, which forms as prescribed ; the chief of the platoon commands HALT, after having marched *twenty* paces.

The other platoons continue to march in column by fours, and form successively at the commands : 1. *Form platoon* ; 2. MARCH, given by their chiefs in sufficient time to command HALT, when the first four files of their platoon arrive at *six* paces from the platoon which precedes.

When the column is at the *trot*, the same principles are conformed to, except that instead of halting, the first two or four files of the first platoon pass to the *walk*, at the command MARCH given by their chief. The other platoons continue to march at the *trot*, and execute their movement at the same gait, the first two or four files of each platoon passing also to the *walk*, at the command MARCH given by their chiefs, when they arrive at their proper distance.

When the column is at the *gallop*, to form twos, fours, etc., the same principles are observed, the first two or four files of each platoon passing to the *trot* at the command MARCH, given by their chief.

When these formations are executed at the *trot*, and at the *gallop*, the guide is announced by the first captain as soon as the first files have doubled, or the first platoon is formed; in the last case only, each chief of platoon repeats the command of the guide as soon as his platoon is formed.

To Break by Fours, by Twos, and by File; to Form Twos, Fours, and Platoons, in Doubling the Gait.

The squadron marching in column with distance, right in front, to break by fours, in doubling the gait, the first captain commands:

1. *By fours—trot.* 2. MARCH. 3. *Guide left.*

At the first command, repeated by the chief of the first platoon, this officer places himself in front of the first four files, and the particular guide of the right on his right.

At the command MARCH, repeated by the chief of the first platoon, the first four files take *the trot*, the others take *the trot* when they oblique to enter the column.

The other platoons continue to march at the *walk*; their chiefs command successively *by fours—trot*, in sufficient time to command MARCH, the moment the last four files of the preceding platoon commence their oblique movement in order to enter the column.

These principles are applicable to breaking by twos and by file.

When the column is at the *trot*, to break at the *gallop*, the same principles are observed, at the commands: 1. *By fours—gallop*; 2. MARCH; 3. *Guide left.*

When the column is at the *gallop*, these movements are always executed at the same gait.

The squadron marching in column by file, to form twos, in doubling the gait, the first captain commands:

1. *Form twos—trot.*
2. MARCH.
3. *Guide left.*

At the command *form twos trot* and MARCH, successively repeated by the chief of the first platoon, this platoon executes its movement as prescribed in the school of the platoon, and the particular guide of the right moves to the right of the chief of the first platoon.

At the first command, the chiefs of the last three platoons command: *trot*. At the command MARCH, repeated by them, the last three platoons take the *trot*.

The chief of the second platoon, and successively those of the third and fourth, command: *Form twos*, in sufficient time to command MARCH, the moment the first file of their platoons is nearly at its proper distance; the first file then passes to the *walk*.

The squadron marching in column by twos, to form fours, in doubling the gait, the first captain commands:

1. *Form fours—trot.*
2. MARCH.
3. *Guide left.*

Which is executed as prescribed in order to form twos.

The squadron marching in column by fours, to form platoon, in doubling the gait, the first captain commands:

1. *Form platoons—trot.*
2. MARCH.
3. *Guide left.*

At the first command, the chief of the first platoon commands: *Form platoon—trot*.

The chiefs of the last three platoons command *trot*.

At the command MARCH, repeated by these officers, the first platoon forms as prescribed in the school of the platoon, and the particular guide of the right places himself on the right of this platoon.

The last three platoons take the *trot*, and form successively at the command *Form platoon*, given by their chiefs in sufficient time to command MARCH, when the first four files arrive at their proper distance from the platoon which precedes them; then these first four files take the *walk*.

The first captain commands *guide left* when the first platoon is formed, and gives a point of direction.

Each chief of platoon repeats successively the command of the guide as soon as his platoon is formed.

When the column is at the *trot*, these formations are executed at the *gallop*, following the same principles, at the commands: 1. *Form twos, or form fours, or form platoons—gallop*; 2. **MARCH**.

The Squadron Marching in Column with Distance, to Face it in the Opposite Direction, and to Face it Again to the Front.

The squadron marching in open column, right in front, the first captain commands:

1. *Platoons left-about wheel.*
2. **MARCH.**

Figure 70. At the first command, the trooper on the left of each platoon, who becomes the pivot, prepares to halt, without however slackening his pace.

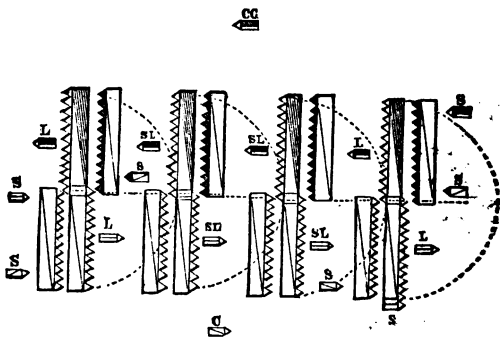

Fig. 70.

At the command **MARCH**, the pivots halt, and the marching flanks wheel at the gait in which the column

was marching, regulating themselves upon the outer flank of the platoon at the head of the column, so as to complete the first half of the movement at the same instant.

The marching flanks are then governed by the platoon, which becomes the head of the column after the movement is completed.

The movement being nearly finished, the first captain commands :

1. FORWARD. 2. *Guide right.*

During this movement, the particular guide of the left places himself on the left of the fourth platoon; the particular guide of the right takes his place as file-closer in rear of the second file from the right of the first platoon, and the other file-closers pass to the side opposite to the guide.

To cause the squadron to resume its primitive direction, the first captain commands : 1. *Platoons right-about wheel*; 2. MARCH; 3. FORWARD; 4. *Guide left.*

To halt the Column.

The column being on the march, to halt it, the first captain commands :

1. *Column.* 2. HALT.

At the first command, all the platoons prepare to halt.

At the command HALT, all the platoons halt at the same time.

To Form Line on the Left.

The squadron being in column with distance, right in front, to form it in line on its left flank, the first captain commands :

1. *Left into line wheel.* 2. MARCH. 3. HALT. 4. *Right—DRESS.* 5. FRONT.

Figure 71. At the first command, the particular guide of the right moves upon the prolongation of the direction of the guides of the column, at the distance of the front of a platoon, facing the side towards which the line will be formed.

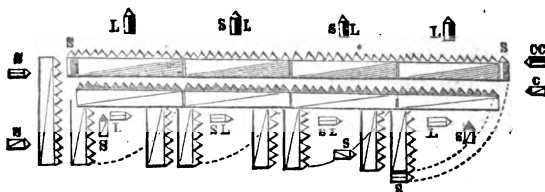

Fig. 71.

At the command **MARCH**, the squadron wheels into line, the trooper on the left wing of each platoon serving as pivot, and turning upon his own ground.

The first captain commands **HALT**, the moment the marching flanks have nearly completed their movement, and then *Right—DRESS*.

At this command, all the platoons align themselves.

The squadron being aligned, the first captain commands **FRONT**.

During the wheel, the particular guide of the left resumes his place in line.

The first captain, after having commanded *left into line wheel*, assures himself, before commanding **MARCH**, that the particular guide of the right is exactly upon the direction of the guides of the column.

Immediately after commanding **HALT**, he moves rapidly to the right flank of the squadron, to observe that the pivots execute their movements properly, and that the officers and troopers align themselves correctly.

The particular guide, who moves upon the prolongation of the guides of the column, should take rather too much ground than not enough. The conductor of the marching flank of the leading platoon should align himself upon his guide, without endeavoring to approach him.

To Break by the Right to March to the Left.

The squadron being in line, the first captain commands :

1. *Platoons break by the right—to march to the left.*
2. **MARCH.**

Figure 72. At the first command, the chief of the first platoon commands: 1. *Platoon forward.* 2. *Guide left.*

At the command MARCH, repeated by the chief of the first platoon, this platoon marches *ten* paces to the front, turns to the left, and moves forward at the commands: 1. *Left—TURN.* 2. FORWARD.

The chief of the second platoon, and successively those of the third and fourth, command: 1. *Platoon forward;* 2. *Guide left;* when the chief of the platoon on their right commands MARCH; and they command

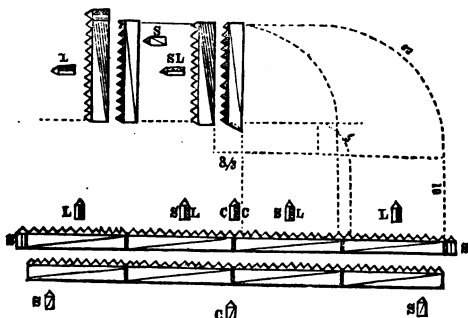

Fig. 72.

MARCH, when the chief of that platoon, after having turned to the left, commands: FORWARD.

To form Line to the Right by Inversion.

The squadron marching in open column, right in front, to form it in line upon its right flank by inversion, the first captain changes the guide; for this purpose, he commands:

Guide right.

The second captain passes by the rear of the column to the side opposite to the guides; the first captain passes by the head of the column to the side of the new

guides, rectifies their direction, then halts the column, and commands :

1. *By inversion right into line wheel.* 2. MARCH.
3. HALT. 4. *Left—DRESS.* 5. FRONT.

During the movement, the particular guide of the left places himself on the right of the fourth platoon, and the particular guide of the right, who moves on the prolongation of the new guides of the column, remains on the left of the first platoon.

To put the squadron again in column, right in front, the first captain commands : 1. *Platoons left wheel.* 2. MARCH. 3. HALT (OR FORWARD). 4. *Guide left.*

To Break to the Rear by the Right to March to the Left.

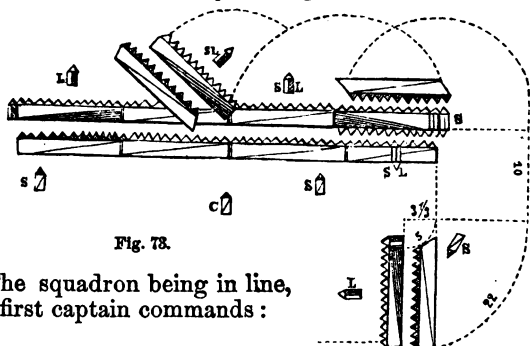

Fig. 73.

The squadron being in line, the first captain commands :

1. *Platoons break by the right to the rear—to march to the left.* 2. MARCH.

Figure 73. At the first command, the chief of the first platoon commands : *Platoon right-about wheel.*

At the command MARCH, repeated by the chief of the first platoon, this platoon executes its wheel to the *right-about*; when nearly terminated, its chief commands : 1. FORWARD; 2. *Guide left*; and after marching *ten* paces straight forward, he commands : 1. *Right—TURN*; 2. FORWARD.

The chief of the second platoon, and successively those of the third and fourth commands : *Platoon right-about*

wheel, when the chief of the platoon on their right commands **MARCH**, and they command **MARCH**, when that platoon has passed over three-fourths of its first wheel.

To Form on Right into Line.

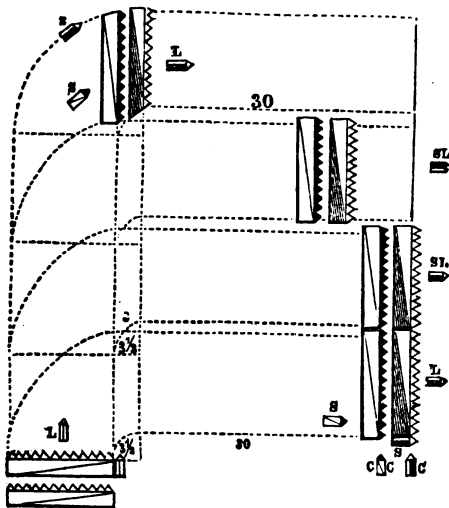

Fig. 74.

The squadron marching in column with distance, right in front, to form it in line on the prolongation and in advance of its right flank, the first captain commands :

1. *On right into line.* 2. **MARCH.**
3. *Guide right.* 4. **FRONT.**

Figure 74. At the first command, the chief of the first platoon commands: *Right.*

At the command **MARCH**, he

commands **TURN**; the platoon turns to the right and moves forward at the command **FORWARD**; when it has marched *thirty* paces, its chief commands: **HALT**, and then *Right*—**DRESS**.

The other platoons continue to march forward, without approaching the line; as soon as each one arrives abreast of the fourth file from the left of the platoon which should be on its right, its chief commands: 1. *Right*—**TURN**; 2. **FORWARD**; this platoon then directs itself towards the place it is to occupy in line, and on arriving abreast of the file-closers, its chief commands: **HALT**, and then *Right*—**DRESS**.

The squadron being aligned, the first captain commands: **FRONT**.

To Form on Left into Line by Inversion.

The squadron marching in column with distance, right in front, to form it in line, upon the prolongation and in advance of its left flank, the captain commands:

1. *By inversion on left into line.* 2. **MARCH.**
3. *Guide left.* 4. **FRONT.**

At the first command, the chief of the first platoon commands: *Left*.

At the command **MARCH**, he commands: **TURN**; the platoon turns to the left, and moves forward at the command **FORWARD**; when it has marched *thirty* paces, its chief commands: **HALT**, and then *Left*—**DRESS**.

The other platoons continue to march forward, without approaching the line; as each platoon arrives abreast of the fourth file from the right of the platoon which should be on its left, its chief commands: 1. *Left*—**TURN**; 2. **FORWARD**; this platoon directs itself towards the place it is to occupy in line, and on arriving abreast of the file-closers, its chief commands: **HALT**, and then *Left*—**DRESS**.

The squadron being aligned, the first captain commands: **FRONT**.

To Break by Platoons to the Front.

The squadron being in line, the first captain commands :

1. *By Platoons to the Front.*
2. MARCH.
3. *Guide left.*

Figure 75. At the first command, the chief of the first platoon commands : *Platoon forward*, and the chiefs of the other three platoons : *Platoon right half wheel*.

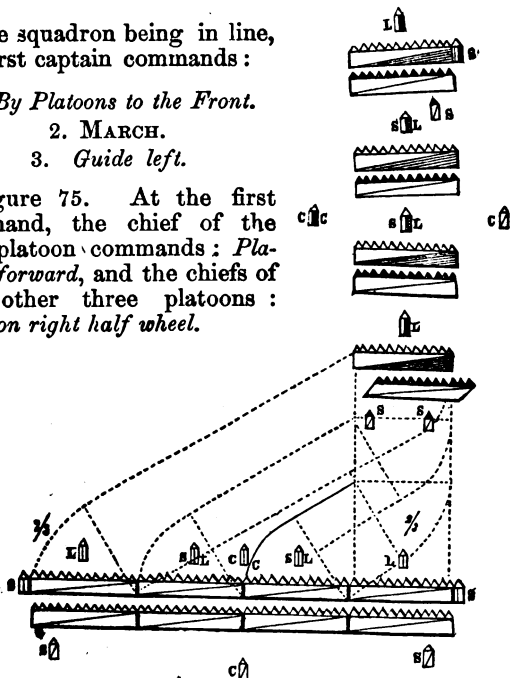

Fig. 75.

At the command MARCH, repeated by these officers, the first platoon moves forward ; its chief repeats the indication of the guide.

Each of the other chiefs of platoon, when their *half-wheel* to the right is executed, commands : 1. FORWARD ; 2. *Guide left*, and then marches straight forward. When the left of his platoon arrives in the direction of the

platoon which precedes, he commands: 1. *Left half-wheel*; 2. MARCH; 3. FORWARD, in order to enter the column.

The first captain does not announce the guide until the first platoon has broken to the front; and he gives the guide a point of direction.

To Form Front into Line.

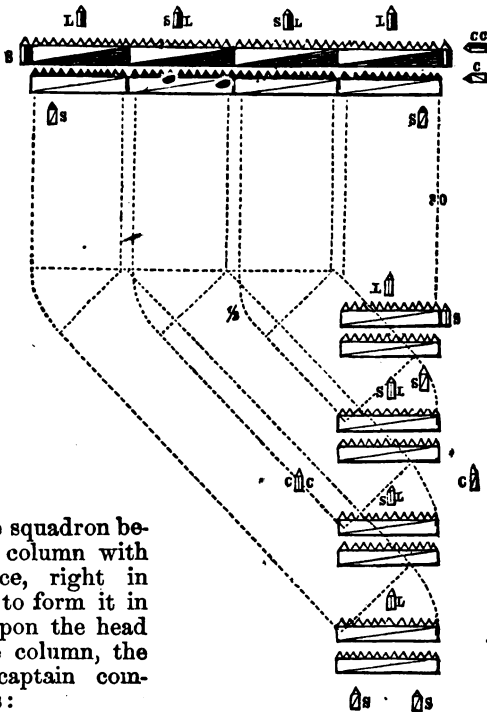

The squadron being in column with distance, right in front, to form it in line upon the head of the column, the first captain commands:

Fig. 76.

1. *Front into line.*
2. MARCH.
3. *Guide right.*
4. FRONT.

Figure 76. At the first command, the chief of the first platoon commands: *Platoon forward*, and the chiefs of the three other platoons command: *Platoon left half wheel*.

At the command MARCH, repeated by these officers, the first platoon moves forward; its chief repeats the indication of the guide, and when it has marched *thirty* paces, he commands:

1. HALT.
2. *Right—DRESS.*

The squadron being aligned, the first captain commands: FRONT.

This formation is executed in the same manner, when the column is on the march; in this case, the chief of the first platoon, continuing to march on, does not command *platoon forward*, nor MARCH, but repeats the indication of the guide.

To Break by Platoons to the Right, and to Move Forward after the Wheel.

The squadron being in line, the first captain commands:

1. *Platoons right wheel.*
2. MARCH.
3. FORWARD.
4. *Guide left.*

At the first command, the left file of each platoon prepares to step off promptly, and the pivot to turn upon itself.

At the command MARCH, each platoon executes its wheel to the right, following the principles of the wheel on a fixed pivot.

At the third command, the platoons march straight forward.

The first captain commands FORWARD, when the

wheels are nearly completed, and gives a point of direction to the guide of the column; he observes that the marching flanks step off at the same instant, wheel and arrive together in column, and that the pivots commence the march together at the command FORWARD.

To Form Line to the Front by Inversion.

The squadron being in open column, right in front, to form line by inversion upon the head of the column, the first captain commands:

1. *By inversion front into line.* 2. MARCH. 3. *Guide left.* 4. FRONT.

At the first command, the chief of the first platoon commands: *Platoon forward*; and the three other chiefs of platoon command: *Platoon right half-wheel.*

At the command MARCH, repeated by these officers, the movement is executed.

To Break by Platoons to the Right, Head of Column to the Left or Half Left.

The squadron being in line, the first captain commands:

1. *Platoons right-wheel—head of column to the left or half left.* 2. MARCH. 3. FORWARD. 4. *Guide left.*

At the command MARCH, each platoon executes its wheel to the right.

At the third command, the chief of the first platoon commands:

1. *Left—TURN.* 2. FORWARD.

The other platoons move on and turn successively at the command of their chiefs, on the ground upon which the first had turned.

The first captain commands, FORWARD, when the wheels are nearly completed, and gives a point of direction.

To Form Line Faced to the Rear, on the Rear of the Column.

The squadron being in column with distance, right in front, to form line faced to the rear, the first captain commands:

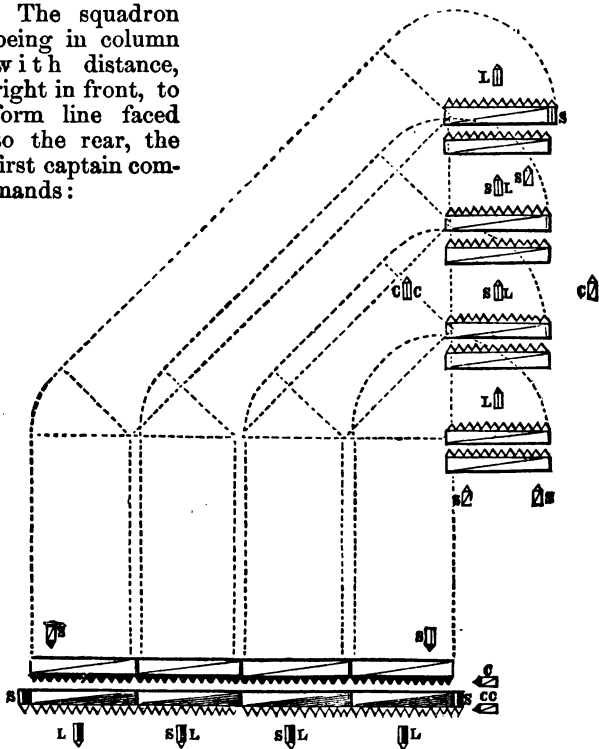

Fig. 77.

1. *Platoons left-about wheel.*
2. *MARCH.*
3. *Front into line.*
4. *MARCH.*
5. *Guide left.*
6. *FRONT.*

Figure 77. At the second command, each platoon executes its wheel to the left-about.

At the fourth command, the chief of the fourth platoon, which becomes the head of the column, when its wheel is nearly completed, commands: 1. FORWARD; 2. *Guide left*; and when it has marched *thirty* paces, 1. HALT; 2. *Left*—DRESS.

The chiefs of the other platoons, on completing three-fourths of their wheel, command: 1. FORWARD; 2. *Guide left*; and direct themselves towards the place they are to occupy in line, conforming in other respects to what is prescribed for *front into line*, when the column has its *left in front*.

The first captain commands *front into line*, in sufficient time to command MARCH, and *guide left*, when the platoons have completed three-fourths of their wheel.

To Form Line Faced to the Rear, by Inversion, on the Rear of the Column.

The squadron being in column with distance, right in front, and obstacles are presented upon its left flank, to form line faced to the rear, the first captain commands:

1. *Platoons right-about wheel.*
2. MARCH.
3. *By inversion front into line.*
4. MARCH.
5. *Guide right.*
6. FRONT.

At the second command, each platoon executes its wheel to the *right-about*.

At the fourth command, the chief of the fourth platoon, which becomes the head of the column, when its wheel is nearly completed, commands: 1. FORWARD; 2. *Guide right*; and when it has marched *thirty* paces, 1. HALT; 2. *Right*—DRESS.

The chiefs of the platoons, at three-fourths of the wheel, command; 1. FORWARD; 2. *Guide right*; and direct themselves towards the place they are to occupy in line, conforming, in other respects, to what is prescribed for *by inversion front into line*, when the *left is in front*.

To Break by Platoons to the Right ; Head of Column to the Right (or Half Right).

The squadron being in line, the first captain commands :

1. *Platoons right wheel—head of column to the right (or*

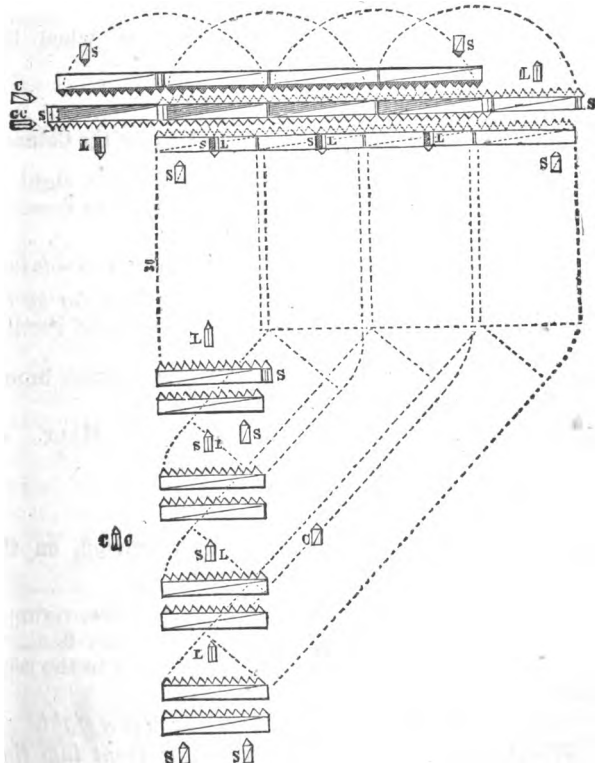

Fig 7A.

half right). 2. MARCH. 3. FORWARD. 4. *Guide left*.

At the command MARCH, each platoon executes its wheel *to the right*.

At the third command, the chief of the first platoon commands: 1. *Right*—TURN; 2. FORWARD. The other platoons move on, and turn successively at the command of their chief, on the same ground.

The first captain commands, FORWARD, when the wheels are nearly completed.

To Form Line Faced to the Rear on the Head of the Column.

The squadron being in column with distance, right in front, to form line upon the head of the column faced to the rear, the first captain commands:

1. *By inversion front into line*. 2. MARCH. 3. *Guide left*.

Fig. 78. Which is executed as prescribed for *by inversion front into line, right in front*, but without rectifying the alignment.

The squadron being formed, the first captain immediately commands:

1. *Platoons left-about wheel*. 2. MARCH. 3. HALT. 4. *Right*—DRESS. 5. FRONT.

To Form Line Faced to the Rear, by Inversion, on the Head of the Column.

The squadron being in column with distance, right in front, and obstacles are presented on its right flank, to form line upon the head of the column, faced to the rear, the first captain commands:

1. *Front into line*. 2. MARCH. 3. *Guide right*.

Which is executed as prescribed for *front into line, right in front*, but without rectifying the alignment.

The squadron being formed, the first captain immediately commands :

1. *Platoons right-about wheel.* 2. MARCH. 3. HALT. 4. *Left—DRESS.* 5. FRONT.

Movements by Fours, the Squadron being in Column with Distance.

To gain distance towards a flank.

The squadron being in column with distance, right in front, to cause it to gain ground towards its left flank, the first captain commands :

1. *By fours left wheel.* 2. MARCH. 3. FORWARD. 4. *Guide right.*

Fig. 79. At the command MARCH, the wheels are executed in each rank by fours, as prescribed in the School of the Platoon.

If, instead of moving forward, after having *wheeled to left by fours*, the first captain wishes to halt the column, he commands : HALT.

To take a direction parallel to the first, and return to column with distance, the first captain commands :

1. *By fours right wheel.* 2. MARCH. 3. HALT.

Which is executed on the same principles, but by inverse means.

If, instead of halting, the first captain wishes the column to march forward, he commands : 1. FORWARD ; 2. *Guide left.*

The squadron being in column with distance, right in front, it is caused to gain ground towards its right flank, by the commands : 1. *By fours right wheel* ; 2. MARCH ; 3. FORWARD ; 4. *Guide left* ; and to resume the primitive direction, at the commands : 1. *By fours left wheel* ; 2. MARCH ; 3. HALT (or FORWARD) ; 4. *Guide left.*

To march to the rear.

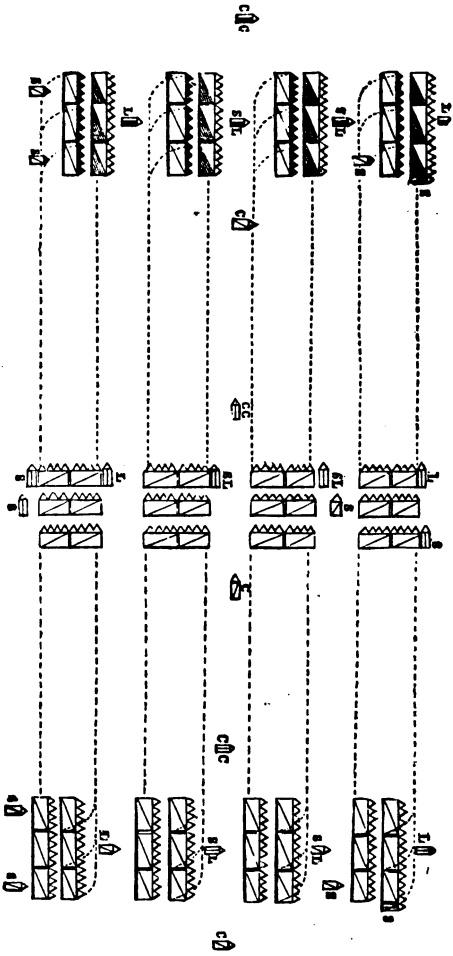

Fig. 79.

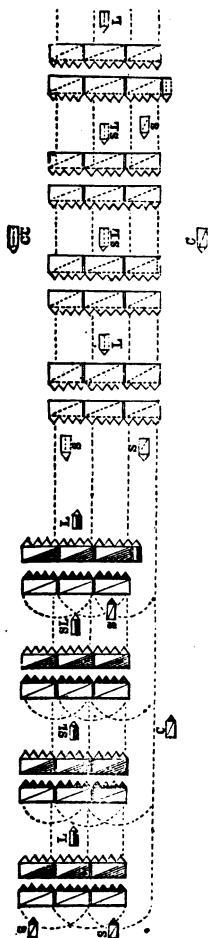

Fig. 80

The squadron being in column with distance, right in front, to cause it to march to the rear, the first captain commands :

1. *By fours left-about wheel.* 2.
- MARCH. 3. FORWARD.
4. *Guide right.*

Fig. 80. At the command MARCH, the movement is executed, in each rank by fours, as prescribed in the School of the Platoon.

If, instead of moving forward after the *wheel to the left-about by fours*, the first captain wishes to halt the column, he commands : HALT.

To return to the primitive direction, the first captain commands :

1. *By fours right-about wheel.* 2.
- MARCH. 3. HALT.

Which is executed as just prescribed, but by inverse means.

If the first captain wishes the column to march forward, he commands : 1. FORWARD ; 2. *Guide left.*

In all the movements *to the left* and *to the right by fours*, the chiefs of platoon move up abreast of the first rank of their platoons, on the side of the guide.

ARTICLE THIRD.

Direct March of the Squadron in Line.

The principles of the direct march, prescribed, in the School of the Platoon, are applicable to the squadron.

The troopers, to keep aligned, should feel lightly the boot of the men on the side of the guide; this principle is borne constantly in mind, as it is the only means of being at ease in the ranks, and preserving the individual alignment. With respect to the general alignment, the non-commissioned officers and flank files endeavor to remain aligned between each other; consequently they will not be required to keep the eyes to the front, but

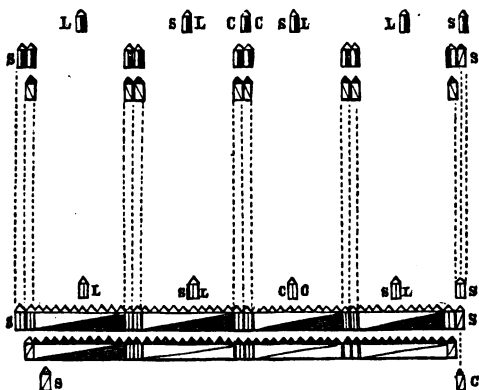

Fig. 81.

from time to time will give a glance towards the guide, in order to keep on the same line, avoiding to carry the bridle hand in that direction, that there may be no crowding in the ranks.

The regularity of the march in line depending much

upon the attention which the flank files pay to their alignment, these files should be at first exercised separately.

The squadron being in line and correctly aligned, the first captain commands :

1. *Flank files forward.*
2. *Guide right.*
3. **MARCH.**

Figure 81. At the second command, the particular guide of the right moves up abreast of the chiefs of platoon ; he is immediately replaced by the file-closer of the first platoon.

At the command **MARCH**, the chiefs of platoons, the flank files (right and left file of each platoon), and the particular guides, move straight forward, the flank files preserving between each other the necessary interval, in order to receive the troopers of their platoons, and when they have marched *thirty* paces, the first captain commands :

1. *Flank files.*
2. **HALT.**

At the command **HALT**, the chiefs of platoon, the flank files, and the particular guides halt.

The first captain, after being assured that the flank files have marched in a direction perpendicular, and upon a line parallel to the front of the squadron, commands :

1. *Squadron forward.*
2. *Guide right.*
3. **MARCH.**

At the command **MARCH**, the flank files and the squadron move forward.

The flank files and the squadron having marched correctly in the given direction, to halt them, the first captain commands :

1. *Squadron.*
2. **HALT**

At the command **HALT**, the squadron and the flank files halt.

To cause the platoons to reënter their places, the first

captain, after giving notice to the flank files to stand fast, commands :

1. *Squadron forward.* 2. MARCH.

And when at *one* pace from the flank files, he commands :

1. *Squadron.* 2. HALT. 3. *Right—DRESS.* 4. FRONT.

At the second command, the troopers halt.

At the third command, the particular guide and the file-closer who replaced him in the front rank of the squadron resume their places in the line; the troopers return to their intervals together, and dress to the right.

The squadron being aligned, the first captain commands : FRONT.

The squadron being in line, to move forward, the first captain commands :

1. *Squadron forward.* 2. *Guide right.* 3. MARCH.

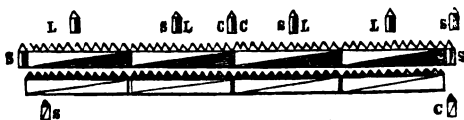

Fig. 82.

Fig. 82. At the second command, the particular guide and file-closer of the first platoon conform to what is prescribed.

At the command MARCH, the squadron moves forward.

To halt the squadron, the first captain commands :

1. *Squadron.* 2. HALT. 3. *Right—DRESS.* 4. FRONT.

At the second command, the squadron halts.

At the third command, the squadron aligns itself as prescribed.

The squadron being aligned, the first captain commands : FRONT.

Counter-March.

The squadron being in line, to face it in the opposite direction, the first captain commands:

1. Counter-march by the right flank. 2. By file to the right. 3. MARCH.

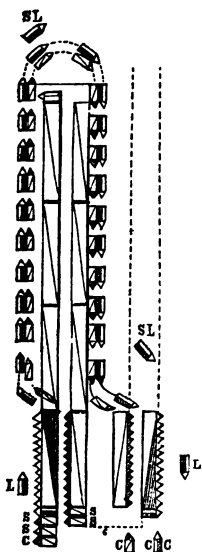

Fig. 83.

Figure 83. At the second command, the chiefs of platoon turn to the right, the chief of the first platoon placing himself in front of his first file; the file-closers turn to the left, and pass to the left of the squadron, those of the second division abreast of the front rank, the second captain on their left, those of the first division abreast of the rear rank.

The particular guide of the right places himself promptly behind the particular guide of the left, facing to the rear, the croup of his horse six paces from the rear rank.

At the command MARCH, the movement is executed as prescribed in the School of the Platoon.

When the first file is at two paces from the particular guide who indicates the place where it is to form, the first captain commands:

1. FRONT. 2. HALT. 3. Right—DRESS. 4. FRONT.

The file-closers follow the movement, and resume their places as they arrive at them.

After having commanded MARCH, the first captain moves rapidly to the flank by which the movement is executed, in order to direct the head of the column, and

to re-form the squadron to the rear upon a line parallel to the one it first occupied.

At the command **HALT**, and *Right—DRESS*, the second captain *turns-about* and places himself abreast of the rear rank to align it.

The squadron being aligned, the first captain commands: **FRONT**. At this command, the chiefs of platoon face to the front, by a turn *to the left*.

The counter-march should be executed generally at the *trot*. For this purpose, after the second command, the first captain indicates the gait.

Wheelings.

The principles prescribed for the platoon are applicable to the squadron wheeling on a fixed or a moveable pivot. The execution of it becomes more difficult as the front is extended; it requires, on the part of the officers and troopers, a particular and constant attention.

To Wheel on a Fixed Pivot.

The squadron is exercised in wheeling on a fixed pivot, first at the *walk*, then at the *trot*; also at the *gallop*, when the troopers are confirmed in all the principles.

The squadron being halted and correctly aligned, the first captain commands:

1. *Squadron in circle right wheel.* 2. **MARCH.**

Which is executed as prescribed in the School of the Platoon.

To halt the squadron during the wheel, the first captain commands:

1. *Squadron.* 2. **HALT.** 3. *Left—DRESS.* 4. **FRONT.**

At the first command, the troopers of the rear rank straighten their horses, and resume their places behind their file-leaders.

At the second command, all the troopers halt.

At the third command, the squadron dresses to the left.

The squadron being aligned, the first captain commands: **FRONT**.

If, instead of halting, the first captain wishes to resume the direct march, he commands :

1. **FORWARD**. 2. *Guide left*.

At the first command, the troopers of the rear rank straighten their horses, and place themselves behind their file-leaders, and the whole squadron moves forward at the gait in which it was marching before the wheel.

The squadron wheeling to the right, at the *walk* or at the *trot*, the first captain commands :

1. *Squadron in circle left wheel*. 2. **MARCH**.

At the first command the rear rank men return to the direction of the file leaders. At the command **MARCH** the left flank halts and becomes the pivot. The right flank assuming the gait at which the left was marching, moves forward and describes a circle proportionate to the extent of the front. All the other troopers straighten their horses, and guide them so as to pass over new circles in an inverse sense.

The squadron being halted, the first captain commands :

- | | |
|----------------------|---|
| 1. <i>Squadron</i> . | } <i>right (or left) wheel.</i>
<i>right-about (or left-about) wheel.</i>
<i>right-half (or left-half) wheel.</i> |
| 2. MARCH . | |
| 3. <i>Squadron</i> . | |
4. **HALT**. 5. *Left (or right)*—**DRESS**. 6. **FRONT**.

Figure 84. Which is executed as prescribed in the School of the Platoon.

The first captain allows sufficient time to elapse between the first and second command, for the troopers to gather their horses, that they may commence to move together.

These movements are executed at the different gaits; but they should not be repeated too frequently at the *gallop*, in order not to fatigue the horses.

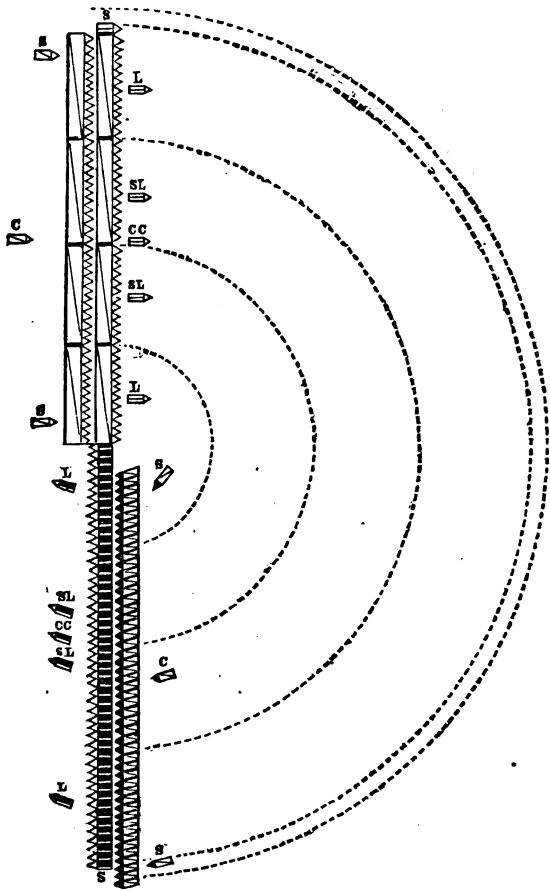

Fig. 84.

To Wheel on a Moveable Pivot.

In the wheels on a moveable pivot, the pivot should describe *an arc of circle of twenty paces*, at the same time slackening the gait; the marching flank increases its gait. The sixth file of the second platoon, which is the middle of the radius of the wheel, preserves the gait a

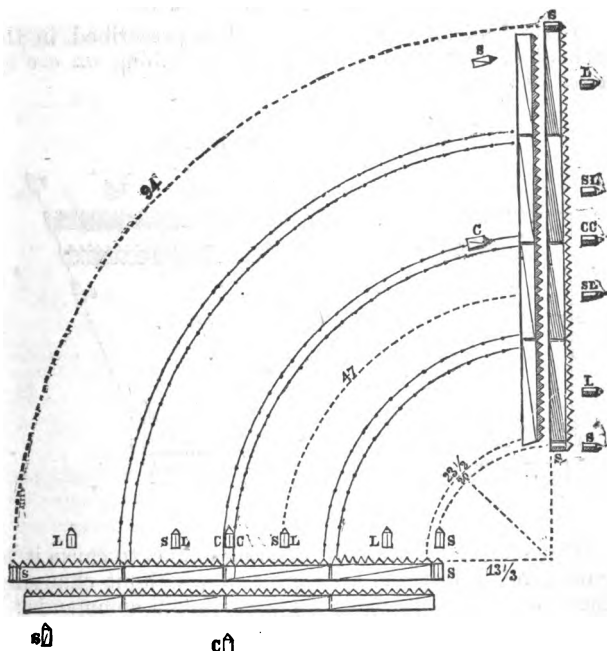

Fig. 85.

which the squadron was marching. The troopers placed between this file and the pivot diminish proportionally their gait; those placed between this file and the marching flank augment proportionally theirs.

The wheel on a moveable pivot is executed upon the guide or upon the opposite flank.

After a wheel on a moveable pivot, the guide remains where it was before the wheel, and is given a new point of direction.

The squadron marching in line, to change direction to the right, the first captain commands :

1. *Right*—TURN. 2. FORWARD.

Figure 85. Which is executed as prescribed, in the School of the Platoon, the pivot describing *an arc of circle of twenty paces*.

Individual Oblique March.

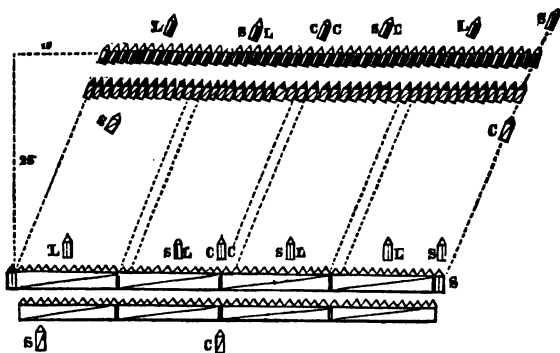

Fig. 86.

Fig. 86. The squadron marching in line, to cause it to gain ground towards its right flank, without changing the front of the squadron, the first captain commands :

1. *Right oblique*. 2. MARCH.

To resume the primitive direction, the first captain commands :

FORWARD.

This is executed as prescribed in the School of the Platoon.

Oblique March by Platoons.

The squadron being in line, to cause it to gain ground towards its right flank, by the oblique march by platoons, the first captain commands :

1. *Platoons right half-wheel.* 2. MARCH. 3. FORWARD.
4. *Guide right.*

Fig. 87. At the command MARCH, each platoon executes its *half-wheel to the right*, on a fixed pivot.

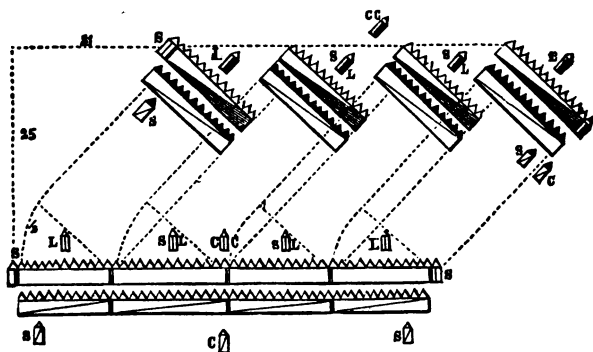

Fig. 87.

At the third command, each platoon moves forward, conforming to the principles of the direct march.

To cause the squadron to resume the primitive direction, the first captain commands :

1. *Platoons left half-wheel.* 2. MARCH. 3. FORWARD.
4. *Guide right.*

Which is executed as just prescribed, but by inverse means.

In the oblique march by platoons, the pivots of the platoons should all halt at the same instant, at the com-

mand MARCH, so that all the wheels may terminate at the same time.

During this march, the right guide of the first platoon marches directly upon the point which has been indicated to him. The guides of the other platoons preserve their distances, take for file-leader the fourth trooper from the left of the platoon which precedes them, and keep at *two* paces from him.

Movements by Fours.

To gain ground to the right.



The squadron being in line, to cause it to gain ground towards its right flank, the first captain commands :

1. *By fours right-wheel.*
2. MARCH.
3. FORWARD.
4. *Guide left.*

Fig. 88. Which is executed as prescribed. The chiefs of platoon march on the side of the guide, at one pace from, and abreast of the leading files of their platoons.

The particular guide of the right marches in front of the column, at one pace from the leading rank of eight, the particular guide of the left behind the last rank of eight of the fourth platoon.

The squadron having wheeled to the right by fours, and being in column, to

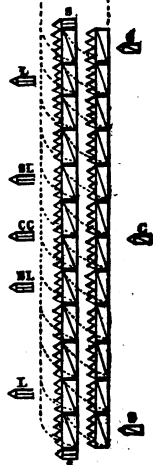

Fig. 88.

change direction to the left, the first captain commands :

Head of column to the left.

The chief of the first platoon commands : 1. *Left—TURN* ; 2. *FORWARD*.

To change direction to the right, the movement is executed on the same principles, but by inverse means, at the command : *Head of column to the right.*

To put the squadron again in line, the first captain commands :

1. *By fours left wheel.* 2. *MARCH.* 3. *HALT.* 4. *Right*
—*DRESS.* 5. *FRONT.*

These movements are executed by the left, on the same principles, at the commands : 1. *By fours left-wheel* ; 2. *MARCH* ; 3. *FORWARD* ; 4. *Guide right* ; and 1. *By fours right-wheel* ; 2. *MARCH* ; 3. *HALT* ; 4. *Left*
—*DRESS* ; 5. *FRONT.*

The Squadron being in Line, to Cause it to Gain Ground to the Rear, and to Face it again to the Front.

The squadron being in line, to face it in the opposite direction, the first captain commands :

1. *By fours right-about wheel.* 2. *MARCH.* 3. *FORWARD.* 4. *Guide left.*

Fig. 89. Which is executed as prescribed in the School of the Platoon.

The chiefs of platoon, the file-closers, and the particular guides, *wheel-about* individually, and march, the chiefs of platoon behind the centre of their platoons, the file-closers in front, and the particular guides abreast of the rear rank, become the front.

At the fourth command, the file-closer nearest the guide passages to the left, in order to place himself in front of the particular guide ; the first captain gives him a point of direction, which is also indicated to the

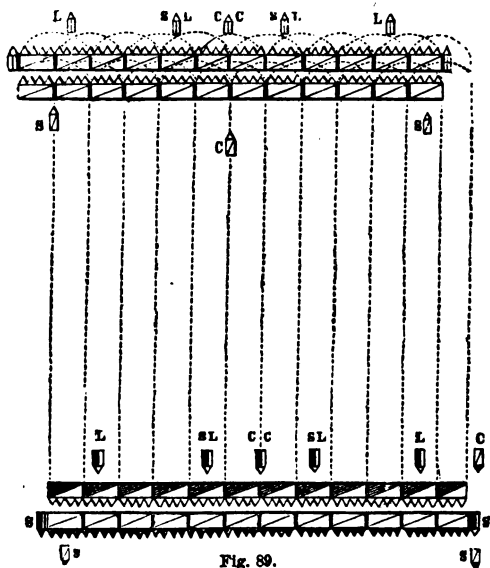

Fig. 89.

particular guide, who, in this movement, remains on the flank of the squadron.

The squadron is *faced again to the front*, by a movement similar to the one just stated.

The *wheels to the left-about by fours*, are executed on the same principles, but by inverse means.

These movements *by fours* are executed from a halt, and in marching at the *walk* and at the *trot*.

The Squadron Marching in Line, to Break it by Platoons, to the Right, and to form it again in Line.

The squadron marching in line, to cause it to gain ground towards its right flank, the first captain commands :

1. *Platoons right-wheel.* 2. MARCH. 3. FORWARD. 4
Guide left.

Which is executed as prescribed, the pivots halting short, and the left file of each platoon stepping out promptly and regulating its movements upon that of the platoon which is in front, so as to arrive together in column.

To put the squadron again in line, the first captain commands :

1. *Platoons left wheel.* 2. MARCH. 3. FORWARD. 4.
Guide right.

The marching flanks regulate their movements upon those of the platoon at the head of the column, so as to arrive together in line.

The second captain gives a point of direction to the particular guide, who moves up on the line of officers, and indicates it also to the file-closer who replaces him on the flank of the squadron.

**The Squadron marching in Line, to march it to the Rear
by Wheeling the Platoons about.**

The squadron marching in line, guide right, the first captain commands :

1. *Platoons right-about wheel.* 2. MARCH. 3. FORWARD.
4. *Guide left.*

Fig. 90. At the command MARCH, the pivots halt short, and turn upon themselves ; the marching flanks step off at the same instant, regulating themselves by the right during the first half of the wheel, so as to arrive together in column, and by the left during the second half, so as to arrive together in line. In each platoon, the rear-rank and the file-closers carry the hand towards the marching flank, in order to facilitate the movement.

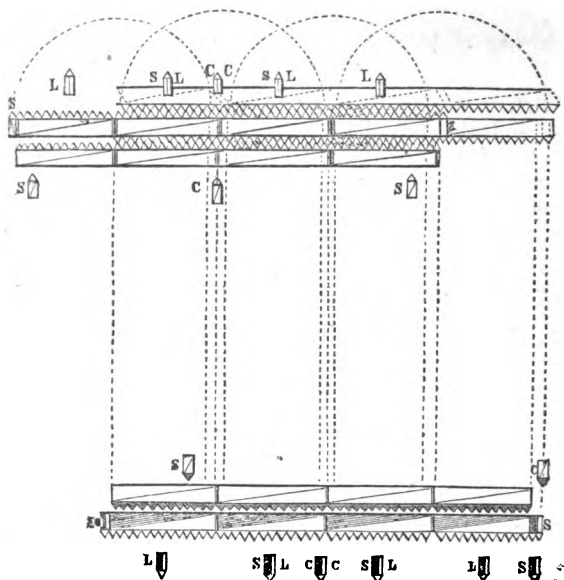

Fig. 90.

At the third command, the squadron resumes the direct march.

At the fourth command, the particular guide on the side indicated moves up on the line of officers; he is immediately replaced, and a point of direction given.

If, after wheeling about, the first captain wishes to halt the squadron, instead of commanding *Forward*, he commands: 3. HALT; 4. *Left*—DRESS; 5. FRONT.

The Squadron marching in Line, to Break it to the Front by Platoons, and to Re-form it.

The first captain commands:

1. *By platoons to the front.* 2. MARCH. 3. *Guide left.*

The squadron marching in column with distance, right in front, to form it at the same gait, the first captain commands :

1. *Form squadron.* 2. MARCH. 3. *Guide right.*

The Squadron Marching in Line; to Break it to the Front by Platoons, in Doubling the Gait, and to Re-form it.

The first captain commands :

1. *By platoons to the front—trot.* 2. MARCH. 3. *Guide left.*

At the first command, the chief of the first platoon

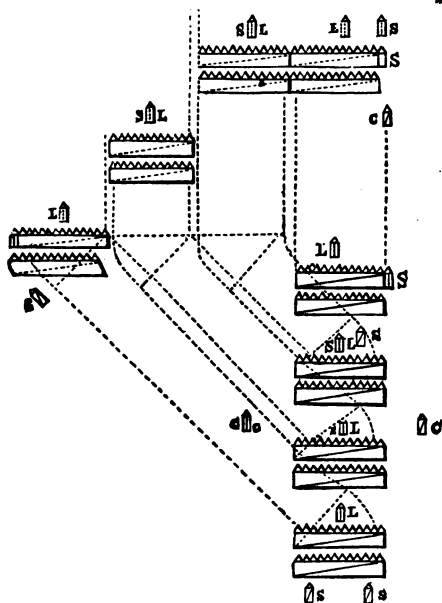

Fig. 91.

commands: *Trot*; and those of the three other platoons command: *Platoon right half-wheel—trot.*

At the command **MARCH**, repeated by these officers, the movement is executed.

To form squadron.

The squadron marching in column with distance, right in front, to form it in doubling the gait, the first captain commands:

1. *Form squadron—trot.* 2. **MARCH.** 3. *Guide right.*

Figure 91. At the first command, the chiefs of the last three platoons command: *Platoon left half-wheel—trot.*

At the command **MARCH**, repeated by the chiefs of the three last platoons, the first platoon continues to march straight forward at the *walk*, and its chief repeats the indication of the guide.

The three other platoons execute their *half-wheel to the left at the trot*, on a fixed pivot.

The half-wheels being nearly terminated, the chiefs of these platoons command: 1. **FORWARD**; 2. *Guide right*; when they move straight forward, and as soon as the right file of their platoon is in the direction of the left file of the platoon, which precedes, they command: 1. *Right half-wheel*; 2. **MARCH**; 3. **FORWARD**; and then, *walk*; in sufficient time to command **MARCH**, when their platoon arrives in line; then the troopers resume the *walk*, and align themselves in marching.

Each platoon, after its *half-wheel to the left*, moves straight forward on the point where it is to turn, and without obliquing toward the platoons which precede it.

The second captain gives a point of direction to the particular guide of the right, who moves upon the line of officers at the command, *guide right.*

Passage of Obstacles.

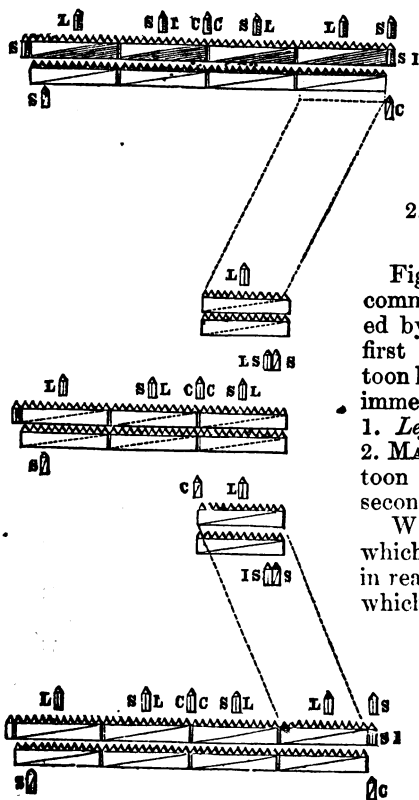

Fig. 92.

The squadron marching in line, to execute the passage of obstacles, the first captain commands:

1. *Obstacle.*
2. *First platoon.*
3. **HALT.**

Figure 92. At the command **HALT**, repeated by the chief of the first platoon, this platoon halts, and its chief immediately commands:

1. *Left oblique — trot;*
2. **MARCH;** and this platoon doubles upon the second.

When the platoon which has obliqued is in rear of the one upon which it has doubled, its chief commands:

1. **FORWARD;**
2. *Guide right;*
3. *Walk;*
4. **MARCH;**

To cause the platoon which has obliqued to return to its

place, the first captain commands:

1. *First platoon.*
2. **INTO LINE.**

At the command **INTO LINE**, the chief of the platoon

commands: 1. *Right oblique—trot*; 2. **MARCH**; when opposite the ground the platoon is to occupy, he commands: 1. **FORWARD**; 2. *Guide left*; 3. *Walk*; and when the platoon is in line, 4. **MARCH**.

The chief of the platoon commands: **FORWARD**, a little before its left file has passed beyond the right file of the platoon on which it is to form.

The squadron marching in line, to execute the passage of obstacles upon the head of each platoon, the captain commands:

1. *In each platoon—by fours (or by twos)—trot.*
2. **MARCH.**
3. *Guide right.*

Figure 93. At the first command, the chiefs of platoon command: *By fours (or by twos)—trot.*

At the command **MARCH**, repeated by these officers, each platoon breaks by fours as prescribed; the chiefs of platoon march at the head of their platoons; the particular guide of the right, who marches on the line of officers, places himself on the right of the chief of the first platoon; the particular guide of the left, in rear of the

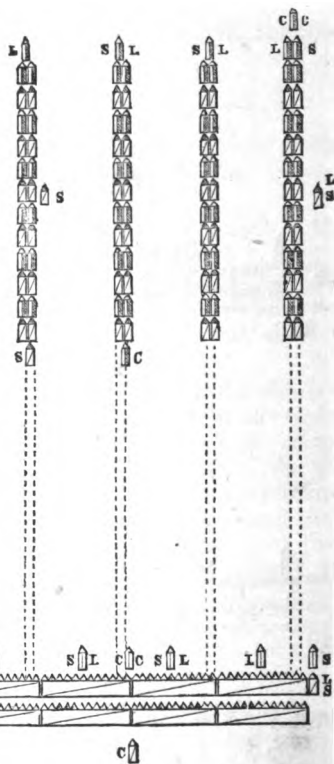

Fig. 93.

fourth platoon, and the file-closers upon the right flank of their platoons.

Each platoon being thus broken in column, should preserve a direction parallel to that of the one which is the guide, keeping on the same line, and always at the distance of its front, to be able at any moment to reform in line.

If the ground requires a platoon to deviate from its direction, it should return to it as soon as possible, and recover its proper distance with respect to the side toward the guide.

In marching thus, the first captain may cause the squadron to break *by twos* and *by file*, observing to form *twos* and *fours* as soon as the ground will permit.

To reform the squadron, each platoon having broken by fours or by twos at the trot, right in front, the first captain commands:

1. *Form platoons.* 2. MARCH. 3. *Guide right.*

At the first command, the chiefs of platoon command: *Form platoon.*

At the command MARCH, repeated by these officers, each platoon forms as prescribed.

If the ground does not permit all the platoons to form at once, the one before which the obstacle is presented, forms in rear of the other platoon of its division, and retakes its place in line as soon as practicable.

ARTICLE FOURTH.

Charge.

In the charge, as in every other direct march, it is important to keep the horses straight. As soon as any confusion is observed, it is necessary to halt and recommence the movement.

The squadron is exercised at the charge: 1. *In line*; 2. *In column*; 3. *As foragers.*

The charge in line is executed by the squadron when

in line; it should be as short as possible, so as to arrive in good order, and without fatiguing the horses.

The charge in column is executed by the squadron broken in column with distance.

To execute *the charge as foragers*, all the troopers of the squadron disperse, and direct themselves each upon the point he wishes to attack, observing not to lose sight of their officers, who charge with them.

The line upon which the squadron should reform after the charge, is marked out by two non-commissioned officers who are file-closers, and who are placed *two hundred and forty* paces in front, facing, and at a distance from each other equal to the front of the squadron.

Non-commissioned officers are also placed opposite the right flank at the different points where the changes of gait should take place.

If the guide is on the left, they are placed opposite the left flank.

The squadron being in line, the first captain orders the sabres to be drawn, and the platoons to charge one after another, commencing by the right.

For this purpose the first captain advances *two hundred and forty* paces to the front, taking a trumpeter with him; and when he wishes the movement to commence, he causes a signal to be given.

The first platoon then moves forward at the commands of its chief. It passes successively from the *walk* to the *trot*, from the *trot* to the *gallop*, and from the *gallop* to the *charge*.

The three other platoons break in their turn, when the preceding one has halted.

To execute the charge by the entire squadron, the first captain places himself in front of the centre of his squadron, and commands:

1. *Squadron forward.*
2. *Guide right (or left).*
3. MARCH.

When the squadron has marched forward *twenty* paces, he commands:

1. *Trot*. 2. MARCH.

At *sixty* paces farther, he commands :

1. *Gallop*. 2. MARCH.

At *eighty* paces farther, he commands :

CHARGE.

When the squadron, after having passed over *sixty* paces at the charge, is *twenty* paces from the non-commissioned officers who mark the line, the first captain commands :

1. *Attention*. 2. *Squadron*. 3. HALT. 4. *Right*—DRESS.
5. FRONT.

At the command *Attention*, repeated by the chiefs of platoon, the troopers prepare to slacken the pace, and carry the sabre to the shoulder.

At the command *Squadron*, the chiefs of platoon command : *Platoon*, and the troopers pass to the *trot*.

At the command HALT, repeated by the chiefs of platoon, the troopers halt.

At the command *Right*—DRESS, they align themselves to the right.

The squadron being aligned, the first captain commands : FRONT.

When the squadron executes the charge correctly, instead of halting when the charge is finished, the first captain commands :

1. *Attention*. 2. *Trot*. 3. MARCH.

At these commands, repeated by the chiefs of platoon, the squadron passes to the *trot*, and at *twenty* paces beyond the line marked out, he commands :

1. *First* (or *fourth*) *platoon*—as *foragers*. 2. MARCH.

At these commands, repeated by the chief of the platoon designated, the platoon moves forward at the *gallop*, and disperses as foragers. A trumpeter follows the chief of the platoon.

The squadron follows this platoon at the *trot* : when

it has passed over *one hundred and fifty* paces, the first captain causes the *rally* to be sounded. At this signal, repeated by the trumpeter of the platoon dispersed as foragers, the latter rally upon the squadron, and when three-fourths of the platoon have rallied and are in line, the first captain commands :

1. *Attention.* 2. *Gallop.* 3. MARCH. 4. CHARGE.

The squadron executes again the charge in line; the troopers who have not been able to rally, charge upon the flanks of the squadron.

The squadron marching in column with distance, *at the trot*, the first captain commands :

1. *To the charge.* 2. MARCH.

At the first command, the chief of the first platoon commands: *Gallop.*

At the command MARCH, repeated by the chief of the first platoon, this platoon commences the *gallop*.

The other platoons follow at the *trot*, each taking the *gallop*, when the platoon which precedes is at the distance of *fifty* paces.

When the first platoon has passed over *eighty* paces at the *gallop*, its chief commands: CHARGE.

At this command, the platoon executes the charge; and when it has passed over *sixty* paces, its chief causes it to pass at the *trot*, by the commands: 1. *Attention*; 2. *Trot*; 3. MARCH.

The other platoons pay attention to the movements of the platoon which precedes them, so as to change the gait in time, and to resume their ordinary distance; the first captain halts the column when he thinks proper.

These charges are executed, each platoon taking in its turn the head of the column.

The squadron marching in column with distance, *at the trot*, the first captain commands :

1. *First platoon as foragers.* 2. MARCH.

At the command MARCH, repeated by the chief of the

first platoon, this platoon disperses as foragers. The squadron continues to march at the *trot*, and when it has passed over *one hundred* or *one hundred and fifty* paces, the first captain causes the *rally* to be sounded.

At this signal, the platoon rallies and reforms at the rear of the column, or at its place in line if the squadron has been put in line.

Rallying.

To give the troopers the habit of rallying promptly, after having been dispersed as foragers, the first captain places the squadron at the extremity of the ground; and after giving notice to the files on the flanks of platoons, the file-closers and the trumpeters, to remain upon the line with him, he causes the *disperse* to be sounded. At this signal, the troopers disperse and charge as foragers; when they are at the distance of *one hundred and fifty* or *two hundred paces*, the first captain causes the *rally* to be sounded.

The first captain observes that the troopers disperse without confusion; that, in rallying, they direct themselves to the right and to the left, outside of the flanks of the squadron, in order to unmask promptly the front of the squadron, and to re-form in passing by the rear.

When the troopers rally without confusion, this movement is repeated without requiring the flank files, etc., to remain on the line of the squadron.

At the signal to *disperse*, the squadron disperses in every direction to the front.

When the squadron is dispersed, the first captain causes the *rally* to be sounded.

At this signal, the officers, the non-commissioned officers, and the troopers, rejoin rapidly; the officers align themselves promptly upon the first captain, and the non-commissioned officers mark immediately the flanks of the platoons.

As soon as the first captain has formed two-thirds

of the squadron, he moves forward, charges again, and halts.

When the squadron is dispersed as foragers, the first captain should sometimes establish himself *to the right* or *to the left* of the direction followed by the troopers, and then order the *rally* to be sounded, to accustom them to rally upon any point he may select.

These movements are first executed *at the trot*, and then *at the gallop*.

Light cavalry should be particularly exercised in *charging as foragers* and in *rallying*.

Skirmishing.

When the squadron is in sight of the skirmishers, the first captain orders no signal except the rally. The chief of the skirmishers observes the movements of the squadron he covers, and conforms to them as soon as practicable, requiring his trumpeter to sound the necessary signals.

When the squadron changes front, the chief of the skirmishers moves upon the new front, unless the first captain gives orders to the contrary.

If the squadron is out of sight of the skirmishers, the first captain causes the signals which correspond to the movements he executes to be sounded, in order to give notice to the chief of the skirmishers, who conforms to them as soon as practicable.

The trumpeter who follows the chief of the skirmishers should give the signals only upon the order of that officer. The skirmishers should execute their movements only by the signals of the trumpeter who accompanies the officer who commands them.

With respect to the signals, as well as to commence and to cease firing, the troopers conform to what is prescribed in the School of the Platoon.

When several platoons act as skirmishers, the firing is commenced by the right of each platoon.

When a squadron is acting as skirmishers, the first captain is always followed by a trumpeter. The others are placed several steps in rear of the line of skirmishers, at equal distances from the centre to the extremities, in order to repeat as soon as possible the signals given by the trumpeter of the first captain.

The squadron being in line, the first captain commands :

1. *First (or fourth) platoon—as skirmishers.*

2. MARCH.

At the first command, the chief of the first platoon orders the sabres to be returned, the holsters to be uncovered, and the arms to be loaded; he then commands : 1. *Platoon forward* ; 2. *Guide right* ; 3. *Trot*.

At the command MARCH, repeated by the chief of the platoon, this platoon moves forward. After marching *one hundred* paces to the front, the chief of the platoon commands : 1. *Six files from right (or from left)—as skirmishers* ; 2. MARCH ; 3. *Guide right (or guide left)* ; which is executed as prescribed.

When the first captain wishes the skirmishers to re-enter the squadron, he causes the *rally* to be sounded.

At this signal, the chief of the skirmishers rallies his platoon, and then rejoins the squadron *at the gallop*, directing himself upon one of the flanks to resume his place in line.

When the first captain wishes to relieve a platoon which is skirmishing, the chief of the new platoon, after causing the arms to be loaded, moves forward upon the reserve of the platoon which is acting as skirmishers. On coming up abreast of it, he orders out *six* files as skirmishers, as has been explained; the remaining *six* files halt and draw sabres.

As soon as the new skirmishers have passed *five* paces beyond those they are to relieve, the latter *turn-about* and rally upon their reserve. The platoon, having rallied, is conducted back to the squadron *at the trot*.

When the entire squadron is to act as skirmishers, the first captain orders the sabres to be returned, the holsters to be uncovered, and the arms to be loaded; he then commands:

1. *Squadron forward.* 2. *Guide right.* 3. *Trot.* 4. **MARCH.**

Having arrived at the point where the reserve is to be established, about *one hundred* paces from the front of the body to be covered, and more if it has been commanded, the first captain commands:

1. *First three (or last three) platoons as skirmishers.*
2. **MARCH.**

At the command **MARCH**, the chief of the platoon which is to support the skirmishers halts that platoon, and orders the sabres to be drawn. The chiefs of the three other platoons continue to march on, each directing himself by the shortest route, *one hundred* paces to the front towards the part of the line his platoon is to occupy, and having reached it, he disperses his platoon as skirmishers.

The right platoon covers the right of the regiment, and extends *thirty* or *forty* paces beyond it; another platoon covers the centre, and the left platoon covers the left, extending also *thirty* or *forty* paces beyond. The chiefs of these platoons remain *twenty-five* paces in rear of the line of skirmishers, and pass over the extent occupied by the troopers of their platoons.

The reserve remains in rear of the centre of the line of skirmishers. If the first captain thinks proper to divide it, each fraction moves upon the point designated, the first commanded by the officer, the other by the non-commissioned officer who was the file-closer.

The first captain, followed by the first sergeant, keeps habitually half way between the reserve and the skirmishers, to direct the movements.

The second captain, followed by the second sergeant, passes the line, and gives notice to the first captain of everything that it is important for him to know.

If the first captain wishes to rally the skirmishers upon themselves, he causes the *rally of skirmishers* to be sounded.

At this signal, each platoon rallies as rapidly as possible upon its chief.

If the first captain then wishes to rally the squadron, he moves upon the point where he intends it shall form, and causes the *rally* to be sounded when three-fourths of each platoon has rallied.

At this new signal, the reserve and each platoon of skirmishers move at a *gallop* upon the point where the captain commanding is placed. The troopers who did not rejoin their platoon when it rallied upon itself, direct themselves towards the squadron.

The squadron being dispersed as skirmishers, if the first captain wishes it to rally immediately, he orders the *rally* to be sounded; at this signal, the officers, the skirmishers, and the reserve, rally upon the point occupied by the first captain.

The troopers being dispersed as skirmishers, if the first captain wishes them to charge as foragers, he orders them to cease firing, and causes the *disperse* to be sounded.

At this signal, the chiefs of platoon move forward in line, and the skirmishers draw sabres; they charge immediately. The reserve follows at the *trot* or at the *gallop*, as may be necessary.

After the charge, the first captain orders the *rally* to be sounded, when the troopers rally in rear of the reserve.

The skirmishers being rallied by platoons, if the first captain wishes to charge, he orders the *charge* to be sounded.

At this signal, each chief of platoon conducts his platoon to the charge in good order; the reserve supports the movement at the *trot* or at the *gallop*.

The platoons rally behind the reserve; the first captain moves upon that point at the same time that he orders the *rally* to be sounded.

The Column by Divisions.

The squadron being in line, if the first captain wishes to form it in column by divisions, he commands :

1. *Divisions right (or left) wheel.* 2. MARCH. 3. HALT (OR FORWARD). 4. *Guide left (or right).*

The principles prescribed for the columns by platoons, are applicable to the march in column by divisions, the different modes of passing from line into column, and from column into line.

To gain ground towards its flanks or to the rear, employ the means prescribed for the column by platoons. The wheels-about can be also executed by divisions.

The distance measured from the croup of the horses of the rear rank of one division, to the head of the horses of the division which follows, should be equal to the front of the division, minus the depth of the two ranks.

In the wheels on a moveable pivot by divisions, the ninth file of the platoon upon which the wheel is executed is the middle point of the radius of the wheel. *The pivot describes an arc of circle of ten paces.*

The squadron marching in column by platoons, right in front, to form the divisions at the same gait, the first captain commands :

1. *Form divisions.* 2. MARCH.

At the first command, the chiefs of the second and fourth platoons command : *Platoon left half-wheel.*

At the command MARCH, repeated by the same officers, the second and fourth platoons execute a *half-wheel to the left* on a fixed pivot. The first and third platoons continue to march straight forward, and having marched *thirty paces*, their chiefs command : HALT.

The chiefs of the second and fourth platoons, when the *half-wheel to the left* is nearly terminated, command : 1. FORWARD; 2. *Guide right*; they move straight forward, and as soon as the right file of their platoon arrives in the direction of the left file of the platoon

which precedes, they command: 1. *Right half-wheel*; 2. **MARCH**; 3. **FORWARD**; they move forward, and command, **HALT**, on arriving abreast of the platoon belonging to the same division.

The lieutenants commanding divisions then command: *Left*—**DRESS**, move to the left of the division, rectify the alignment, command: **FRONT**, and return to the centre of their platoons.

When the column is at the *trot*, to form division, at the same gait, conform to the principles just prescribed, except that the chiefs of the first and third platoons, at the first command, command: *Walk*; at the command, **MARCH**, repeated by them, their platoons pass to the *walk*, continue to march on; and that the chiefs of the second and fourth platoons, which execute their movements in marching at the *trot*, command: *Walk*, in sufficient time to command **MARCH** when their platoons come up abreast of those on which they are to form.

The first captain then commands: *Guide left*.

When the column is at the gallop, to form the divisions at the same gait, conform to the same principles, the first and third platoons passing to the *trot* at the command **MARCH**, and the second and fourth platoons taking the *trot* as they come up.

The column having the left in front, conform to the same principles, the first and third platoons executing in an inverse sense what has been prescribed for the second and fourth; and the latter conforming to what has been prescribed for the first and third.

The squadron marching in column by divisions, right in front, to break the divisions by platoons, the first captain commands:

1. *By platoons.*
2. **MARCH.**
3. *Guide left.*

At the first command, the chiefs of the second and fourth platoons command: *Platoon right half-wheel*.

At the command **MARCH**, repeated by the same officers, the second and fourth platoons execute a *half-wheel*

to the right on a fixed pivot, and the first and third platoons continue to march on.

The chiefs of the second and fourth platoons, the *half-wheel to the right* being nearly terminated, command: 1. FORWARD; 2. *Guide left*; they move straight forward, and as soon as the left file of their platoon arrives in the direction of the left file of the platoon which precedes, they command: 1. *Left half-wheel*; 2. MARCH; 3. FORWARD; and move forward in taking their proper distances.

The divisions are broken by platoons on the same principles, by marching at the *trot* or at the *gallop*.

The column having the left in front, the first captain commands: 1. *By the left—by platoons*; 2. MARCH; 3. *Guide right*, which is executed on the same principles, the first and third platoons executing in an inverse sense what is prescribed for the second and fourth, and the latter conforming to what is prescribed for the first and third platoons.

The squadron marching in column by platoons, right in front, to form divisions in doubling the gait, the first captain commands:

1. *Form divisions—trot.*
2. MARCH.
3. *Guide left.*

Which is executed as prescribed, the first and third platoons continuing to march at the same gait, and the chiefs of the second and fourth platoons commanding: 1. *Platoon left half-wheel—trot*; 2. MARCH; 3. FORWARD; 4. *Guide right*; and 1. *Right half-wheel*; 2. MARCH; 3. FORWARD; 4. *Walk*. When they arrive abreast of the platoon, on which they form, they command: 5. MARCH.

The column marching at the *trot*, the divisions are formed at the *gallop*, on the same principles, at the commands: 1. *Form divisions—gallop*; 2. MARCH; 3. *Guide left*.

When the column is at the *gallop*, the divisions are formed at the same gait, the first and third platoons taking the *trot* at the command: MARCH.

The squadron marching in column by divisions, right in front, to break the divisions by platoons, in doubling the gait, the first captain commands :

1. *By platoons—trot.* 2. MARCH. 3. *Guide right.*

At the first command, the chiefs of the first and third platoons command: *Trot*; those of the second and fourth platoons command: *Platoon right half-wheel—trot.*

At the command MARCH, repeated by the chiefs of platoon, the first and third platoons move forward at the *trot*. The second and fourth execute their *half-wheel to the right* on a fixed pivot, at the *trot*, and the movement is executed as prescribed.

The column being at the *trot* to break by platoons at the *gallop*, conform to the same principles, at the commands: 1. *By platoons—gallop*; 2. MARCH; 3. *Guide left.*

When the column marches at the *gallop*, the divisions are broken at the same gait.

The squadron being in line, to break it by divisions by the right to march to the left, the first captain commands :

1. *Divisions break by the right—to march to the left.* 2. MARCH.

Which is executed as prescribed for the column by platoons, each first lieutenant commanding successively, MARCH, when the division which precedes arrives opposite the centre of the second platoon of his own division.

The same principles are observed, to break by the left to march to the right.

To break the squadron by divisions to the rear by the right, to march to the left, the first captain commands :

1. *Divisions break by the right to the rear—to march to the left.* 2. MARCH.

Which is executed as prescribed for the column by platoons.

PRICE TWO DOLLARS.

FOURTH EDITION,

REVISED, WITH EXTENSIVE ADDITIONS, TO APRIL, 1864.

PATTEN'S
ARMY MANUAL,

CONTAINING

**Instructions for Officers in the Preparation of
Rolls, Returns, and Reports, and all Papers
pertaining to the Duties of the Subsist-
ence, Quartermaster, and Medical
Departments, and the Accounts
connected therewith.**

**Forms of all Returns required of Regimental
and Company Commanders,
etc., etc., etc.**

BY LIEUT.-COLONEL GEORGE PATTEN,

LATE OF THE UNITED STATES ARMY.

This work contains all the Forms used, and the Papers of the Quartermaster's and Subsistence Departments, as they are now required to be made out, with full information how and when they are to be prepared, and to whom they are to be sent—being, in this respect, in advance of the Army Regulations and all other Manuals of Instruction. It also contains Forms and Instructions for the preparation of all the ROLLS, RETURNS, and REPORTS required of Field and Company Officers, none of which are to be found in any other work.

It will be sent free by mail on receipt of price, Two Dollars, by the Publisher,

J. W. FORTUNE,

102 Centre Street, New York.

